

bionic fire™

The Fine Art of Modern Green Living

User Manual for New Zealand and Australia

Bionic fire

New Zealand: Authorisation number: 152619 (AS/NZS 4012/4013)

Authorisation number: 154319 (ULEB)

Australia: Australian Home Heating Association Inc.: H1018/0217

Bionic fire Studio

New Zealand: Authorisation number: 166404 (AS/NZS 4012/4013)

Authorisation number: 166197 (ULEB)

Australia: Australian Home Heating Association Inc.: H1025/0217

Resource Consent Number Environment Canterbury: CRC 155430

Website for authorized burners:

in New Zealand:

<http://solidburner.ecan.govt.nz>

in Australia:

www.certifiedwoodheaters.com.au



EnviroSolve Ltd
Exclusive Agent for New Zealand

Dr Rene Haerberli
Ohakune Road
RD 3
Raetihi

Phone: + 64 6 485 4871

Mobile: + 64 21 24 24 211

Email: info@envirosolve.co.nz

Web: www.envirosolve.co.nz

Contents

- 1. Introduction 4**
 - 1.1 Warranty5
- 2. Bionic fire specification tested with soft wood for New Zealand and hard wood for Australia.6**
- 3. Dimensions of the bionic fire and bionic fire Studio..... 7**
 - 3.1 bionic fire..... 7**
 - 3.2 bionic fire Studio..... 8**
- 4. Installation instructions..... 9**
 - 4.1 Warning: Health and Safety advice notice 10
 - 4.1.1 Handling..... 10
 - 4.1.2 Fire Cement..... 10
 - 4.1.3 Asbestos..... 10
 - 4.1.4 Metal Parts..... 10
 - 4.1.5 Important Warning – Preparatory Work and Safety Checks 10
- 5. Installation..... 11**
 - 5.1 Seismic restraint..... 11
 - 5.1.1 Securing the Fire 12
 - 5.2 Air supply for the bionic fire 12
 - 5.2.1 External Air supply for low energy and passive house 12
 - 5.3 Installation distance in case of combustible walls 18
 - 5.3.1 Clearance Distance – Parallel Position / bionic fire fixed 18
 - 5.3.2 Clearance Distances – Corner Position / bionic fire fixed..... 19
 - 5.3.3 Clearance distances bionic fire with swivel..... 20
 - 5.3.4 Bionic fire Studio Clearance distances 21
 - 5.4 Stoppers for bionic fire with swivel 22
- 6 Installation of the chimney 23**
 - 6.1 Summary flue installation..... 24**
 - 6.1.1 General drawing for the chimney installation 25
 - 6.2 General instruction for installers 26
 - 6.3 Operating instructions 28
 - 6.3.1 Fuel..... 28
 - 6.3.2 Drying and storage 28
 - 6.3.3 Room ventilation and stoves..... 29
 - 6.3.4 Practical Tips for use of the bionic fire..... 29
 - 6.4 Stove functioning 32
 - 6.4.1 Automatic regulation for combustion air 32

- 7. First Use..... 34**
- 8.Important Safety Advice 35**
 - 8.1. Tips before firing up 35
 - 8.2 'Top-down' Lighting 36
 - 8.3 Warning! 38
 - 8.4 Cleaning and Care..... 39
 - 8.4.1 Glass 39
 - 8.4.2 Paint finish 39
 - 8.4.3 Mechanical cleaning 39
 - 8.4.4 Prolonged period of non-use..... 39
 - 8.4.5 Cleaning the combustion chamber..... 40
 - 8.4.6 Cleaning of flue ways 42
 - 8.5 Replacing vermiculite panels in the lower combustion 40
- 9. Interruption of operation43**
 - 9.1 Smoke spillage around the door45
 - 9.2 Soot on glass.....45
 - 9.3 Stove is burning too strong 45
 - 9.4 Stove is burning too weakly 45
- Appendix 46**
 - 1. Drawings for the spare part 46
 - 2. Legend for the spare parts.....47
 - 3. Technical drawing of the bionic fire 48
 - 4. Technical drawing of the bionic fire Studio.....49
 - 5. Through wall penetration kit50
 - 6. Change of Chimney Connection. 51
 - 7. Changing the Vermiculite in the Bionic fire..... 52
 - 8. Fire Box drawings and dimensions.....53
 - 9. NZ Lab Testing Results summaries. 54

This fire is wrapped in packaging that is recyclable.

This must be disposed of according to national waste disposal guidelines.

The glass cannot be reused.

The glass should be discarded along with the residual waste from ceramics and porcelain. Pyrex glass has a higher melting temperature and therefore cannot be reused.

If discarded, you make an important positive contribution to the environment.

1. Introduction

Thank you for purchasing a RAIS wood burning stove.

A RAIS wood burning stove is more than just a heat source. It also shows that you care about design and quality in your home.

To make the most of your wood burning stove it is important that you read the manual thoroughly before installing and using it.

In the case of warranty coverage and for general queries regarding your wood burning stove, it is important that you know the stove's production number. We therefore recommend that you note down the number in the table below. The production number is located on the back of the stove at the bottom.

1.1 Warranty

Your Rais Bionic Fire wood burning stove comes with a 10 year warranty. The warranty, however, does not cover heat-insulating materials, glass and seals.

The appliance must be serviced and maintained using parts approved by the manufacturer, to achieve the proper performance of the appliance.

Any alterations made to the stove will void the warranty.

The name **bionic fire** is a registered trademark.

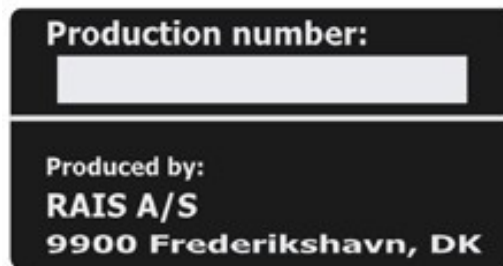

Date:

Distributor: **EnviroSolve Ltd**

Ohakune Road
RD 3
Wanganui
New Zealand

email: rene.haeberli@envirosolve.co.nz
phone: +64 (0) 6 385 4871
mobile: +64 (0) 21 24 24 211
www.envirosolve.co.nz

2. Bionic fire specification tested with soft wood for New Zealand and hard wood for Australia

Nominal Output (kW)	8.5
Min. / Max. Output (kW)	4.6
Heating area (m ²)	100 - 120
Bionic fire Standard width/depth/height (mm)	404 x 411 x 1250
Bionic fire Standard with swivel width/depth/height (mm)	404 x 411 x 1332
Bionic fire Studio width/depth/height (mm)	410 x 409 x 1381
Upper Combustion chamber's width/depth/height (mm)	280 x 200 x 300
New Zealand: Efficiency tested with soft wood	76.0%
Australia: Efficiency tested with hard wood	72.2%
New Zealand: Fuel consumption kg/h with soft wood	1.0 kg
Australia: Fuel consumption kg/h with hard wood	0.73 kg
Recommended amount of fuel when fuelling Distributed 1 -2 logs of wood approx. 25 cm	1.1 kg
Approx. Weight	185 kg
Intermittent operation	Refuelling should be undertaken within 1 1/2 hours

3. Dimensions of the bionic fire and bionic fire Studio

3.1 bionic fire

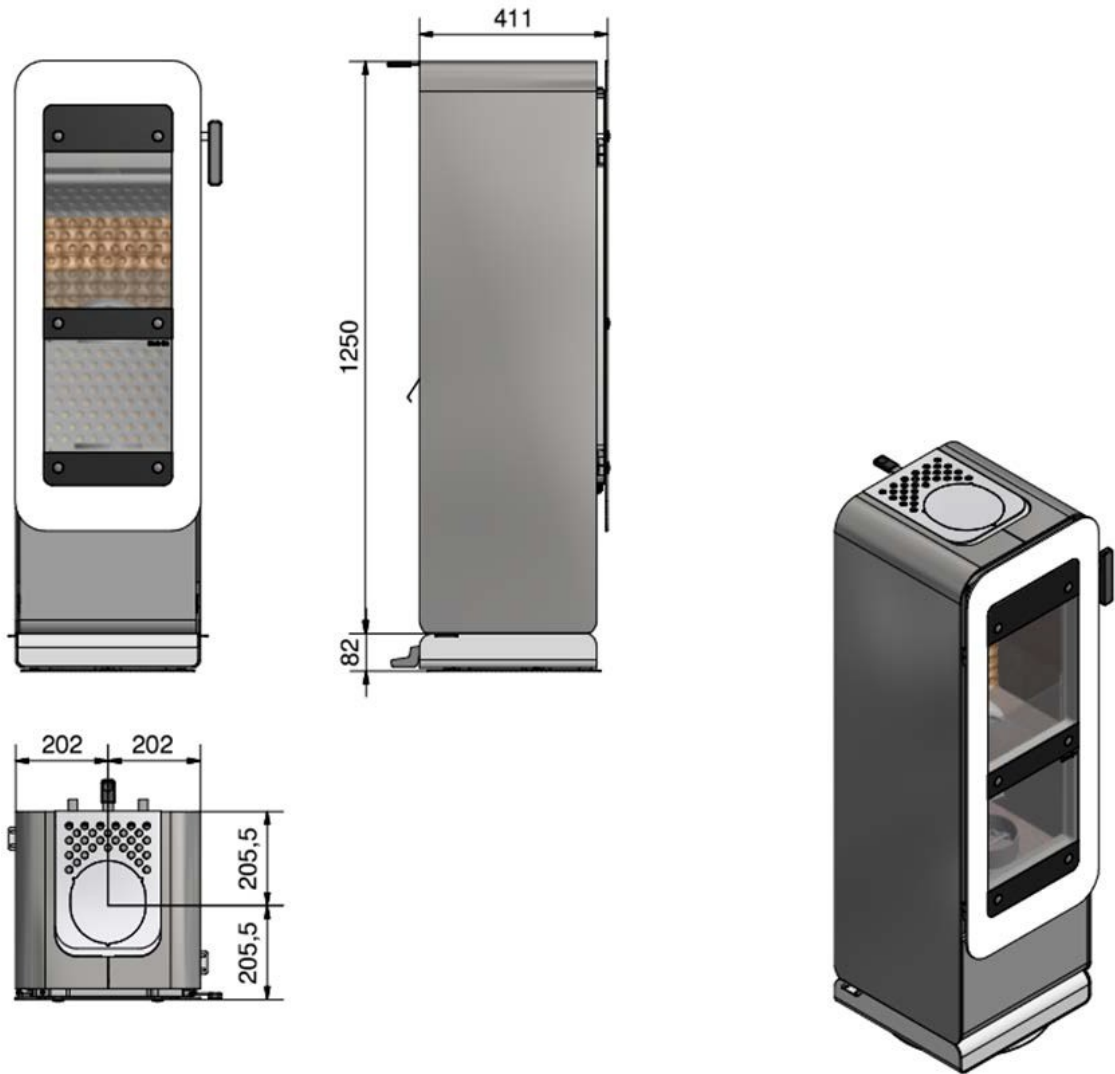

3.2 bionic fire Studio

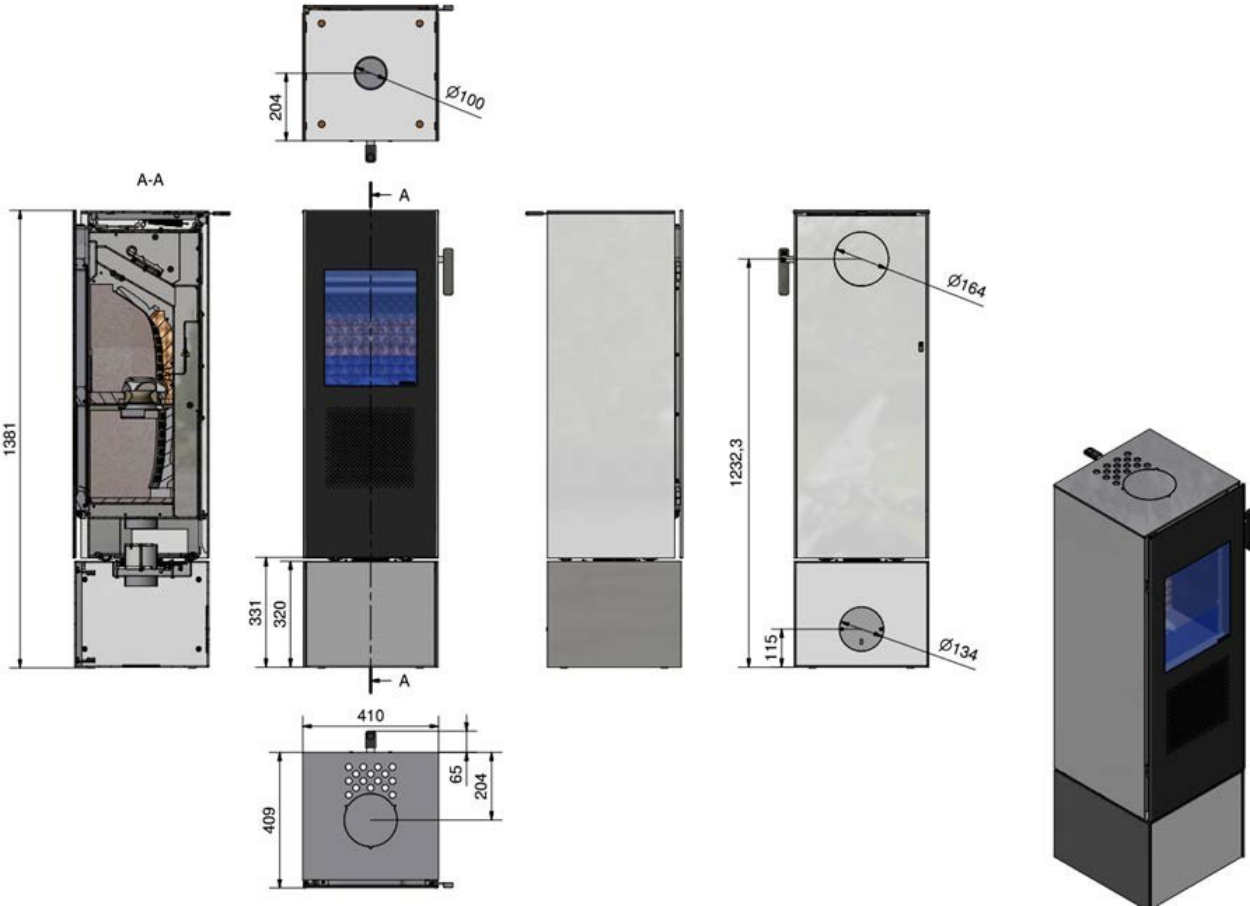

4. Installation instructions

The following pages give instructions for the safe and proper installation of this heating appliance in New Zealand and Australia. These instructions cover the basic principles of installation, although detail may need slight modification to suit particular local site conditions. In all cases the installation must comply with the current New Zealand and Australian Building Regulations, local authority byelaws and other specifications or regulations as they affect the installation of the stove. Please note that it is a legal requirement under New Zealand and Australian Building Regulations that the installation of the stove is either carried out under Local Authority building control approval or is installed by a competent person registered with a government approved licensed installer.

Convection

RAIS stoves are convection stoves. This means that the stove's back and side panels are not over-heated. Convection means that there is a circulation of air, which ensures that the heat is distributed more evenly throughout the entire room. The cold air is sucked in at the base of the stove up through the convection channel, which runs along the stove's combustion chamber. The heated air pours out at the top of the stove, which ensures a circulation of warm air throughout the room. It should be noted that radiant heat from the glass panel door gets very hot up to 600 degrees centigrade. Choosing a swivel Bionic fire gives the user the option to direct the heat of the fire to their sitting position. The radiant heat can be felt 4-5m away from the fire.

4.1 Warning: Health and Safety advice notice

Ensure the heater is installed in accordance with all current local building and safety regulations. Attention is drawn in particular to the following.

4.1.1 Handling

The appliance is a heavy item and adequate facilities must be available for loading, unloading and site handling.

4.1.2 Fire Cement

Some types of fire cement are caustic and should not be allowed to come into contact with the skin. Protective gloves should be worn when handling fire cement. In case of contact with skin the skin should be washed immediately with plenty of water.

4.1.3 Asbestos

This stove contains **no asbestos**. If there is a possibility of disturbing any asbestos during installation, then please seek specialist guidance and use appropriate protective equipment.

4.1.4 Metal Parts

When installing or servicing this stove care should be taken to avoid the possibility of personal injury.

4.1.5 Important Warning – Preparatory Work and Safety Checks

- This stove must not be installed into a chimney that serves any other heating appliance.
- It is recommended not to have an extractor fan fitted in the same room as the stove as this can cause the stove to emit fumes into the room or it should be at least 3 - 4 m away from the bionic fire (very strong kitchen extractor fans).
- If this appliance is installed into an existing chimney, the chimney must first be swept and examined for soundness and suitability before the appliance is installed.

5. Installation

5.1 Seismic restraint

The **bionic fire** is a free-standing stove and has a steel socket.

The stove must be set up and installed in accordance with all current national and local rules and regulations. Local authorities and a chimney specialist should be contacted prior to set up.

An appliance shall be installed with sufficient stability so as not to detract from the intended normal operation of the appliance nor to create a hazard for users of the appliance.

Where required by the regulatory authority, provision shall be made for seismic restraint of the floor protector and the appliance. Sufficient restraint shall be provided to resist a seismic loading equal to 0.4 times the mass of the appliance. The load shall be applied horizontally in any direction at the mid-height of the combustion chamber. The appliance shall not move, tilt or be dislodged from its installed position during application of the load.

New Zealand: The bionic fire must be seismically restrained according to the Standard AS/NZS 2918:2011; paragraph 3.8:

Stability

An appliance shall be installed with sufficient stability so as not to detract from the intended normal operation of the appliance nor to create a hazard for users of the appliance.

3.8 Seismic restraint

Where required by the regulatory authority, provision shall be made for seismic restraint of the floor protector and the appliance. Sufficient restraint shall be provided to resist a seismic loading equal to 0.4 times the mass of the appliance. The load shall be applied horizontally in any direction at the mid-height of the combustion chamber. The appliance shall not move, tilt or be dislodged from its installed position during application of the load.

Notes:

- 1. The seismic loading is to be applied before the flue system is installed*
- 2. Where the appliance is secured to the floor protector the test is to be applied to the combination at a point approximately 100 mm above the top surface of the floor protector.*

It is prohibited to carry out unauthorized alterations to the stove.

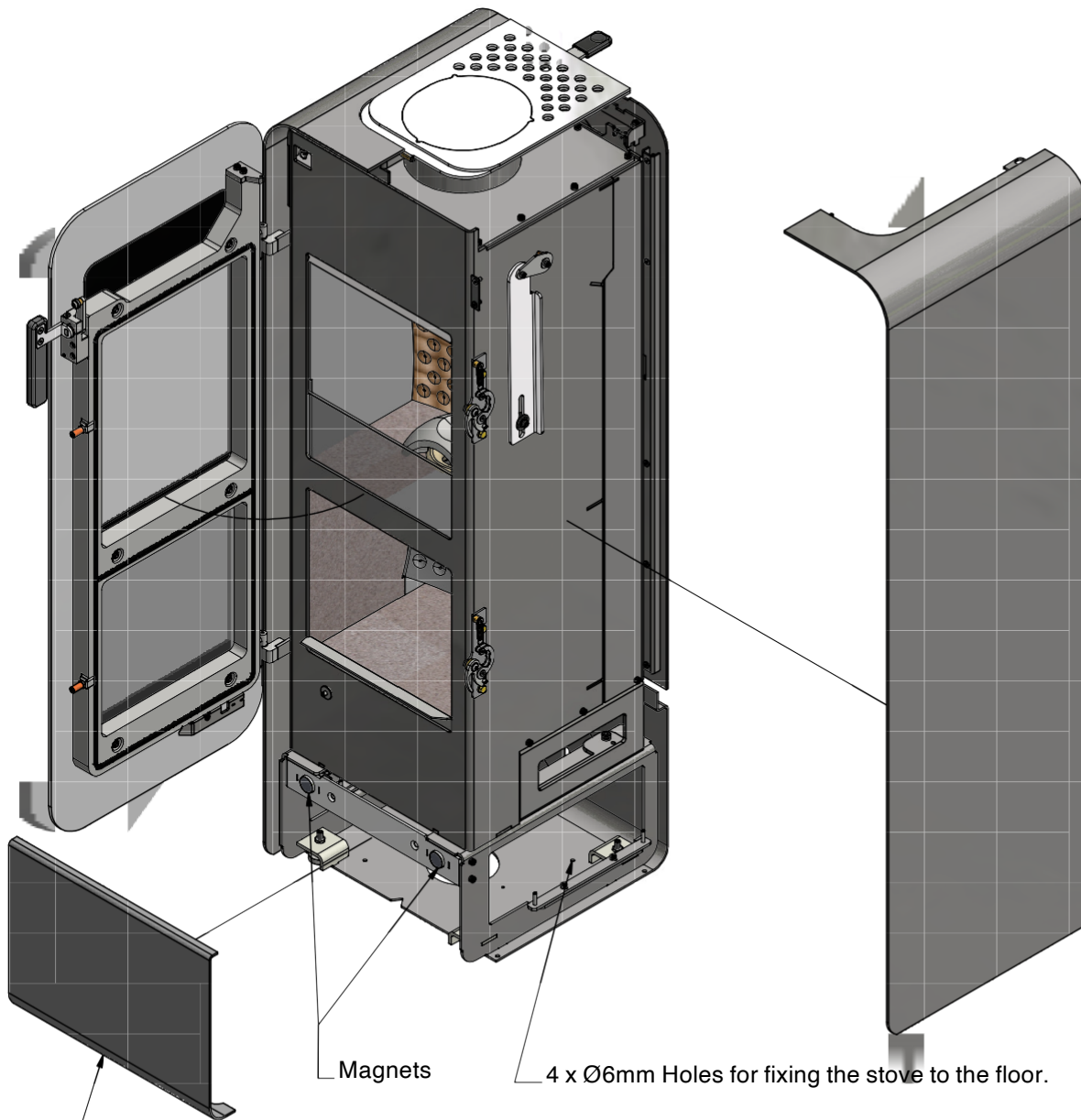

Pull off the front cover of the socket.

Magnets

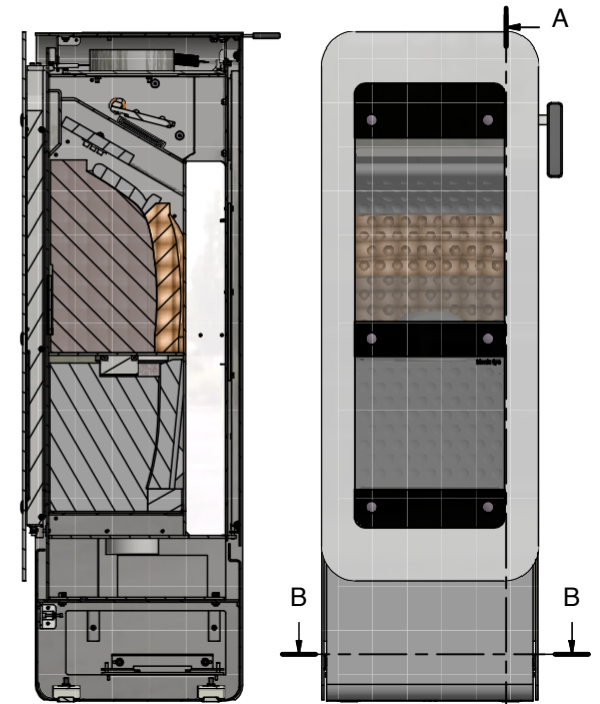

4 x Ø6mm Holes for fixing the stove to the floor.

A-A (0,1)

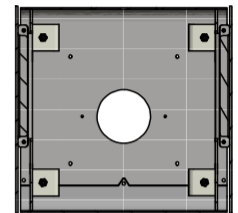

B-B (0,1)



 RAIS [®] ART OF FIRE INDUSTRIVEJ 20, 9900 FREDERIKSHAVN, DENMARK Phone +45 98 47 90 33 - Fax +45 98 47 92 91 E-mail: info@rais.dk - Homepage: www.rais.dk		Designer:	Project manager:	Approved:
		ksj		
		D M Y		
		Corrections:		
Drawing name: Mounting instruction - Fixing the stove to the floor				
Project:	Established:	Format:	Revision:	Drawing no.:
Bionicfire	30-04-2018	A3		8518601

5.1.1 Securing the Fire

1. Remove the adjustable feet from the stove.
2. Use the M8 threads to bolt the fire to the floor

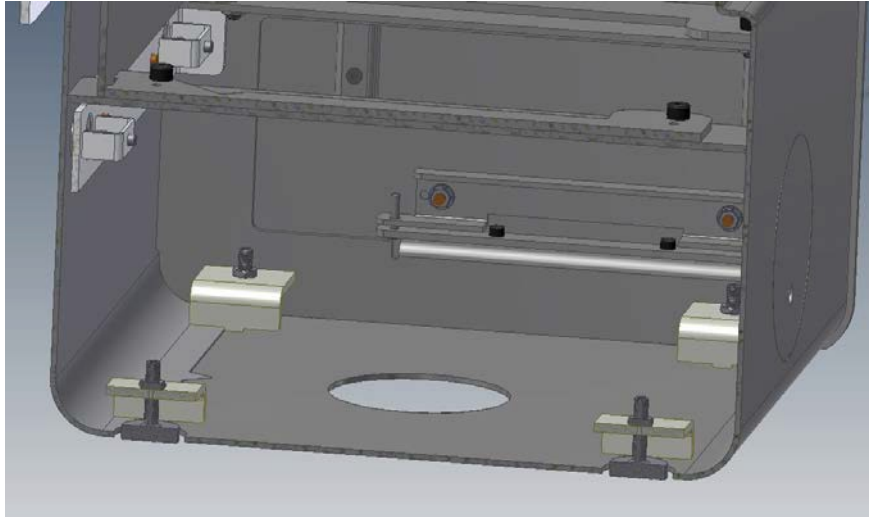

5.2 Air supply for the bionic fire

There must be plenty of fresh air in the room where the stove is being installed, in order to ensure proper combustion. Note that any mechanical exhaust ventilation - i.e. an extraction hood - may reduce the air supply. Any air grates must be placed in such a manner, that the air supply is not blocked.

The floor structure must be able to carry the weight of the wood burning stove as well as the weight of the chimney, if necessary.

The fire is placed on fire proof material.

When you choose where to set up your RAIS wood burning stove, you should consider the heat distribution to the other rooms. This will enable you to get the best use out of your stove. The stove should be set up at a safe distance from inflammable material (Please see clearance requirements against combustible material 5.1.1; 5.1.2; 5.1.3 and 5.1.4).

Upon receiving the stove must be inspected for defects!

5.2.1 External Air supply for low energy and passive house

Low energy and passive houses must have an external air supply for the bionic fire. There are two options either through the wall or through the floor (Bionic fire with a swivel base is the only model that provides for external venting through the floor).

5.2.1.1 Wall option – external fresh air through the wall

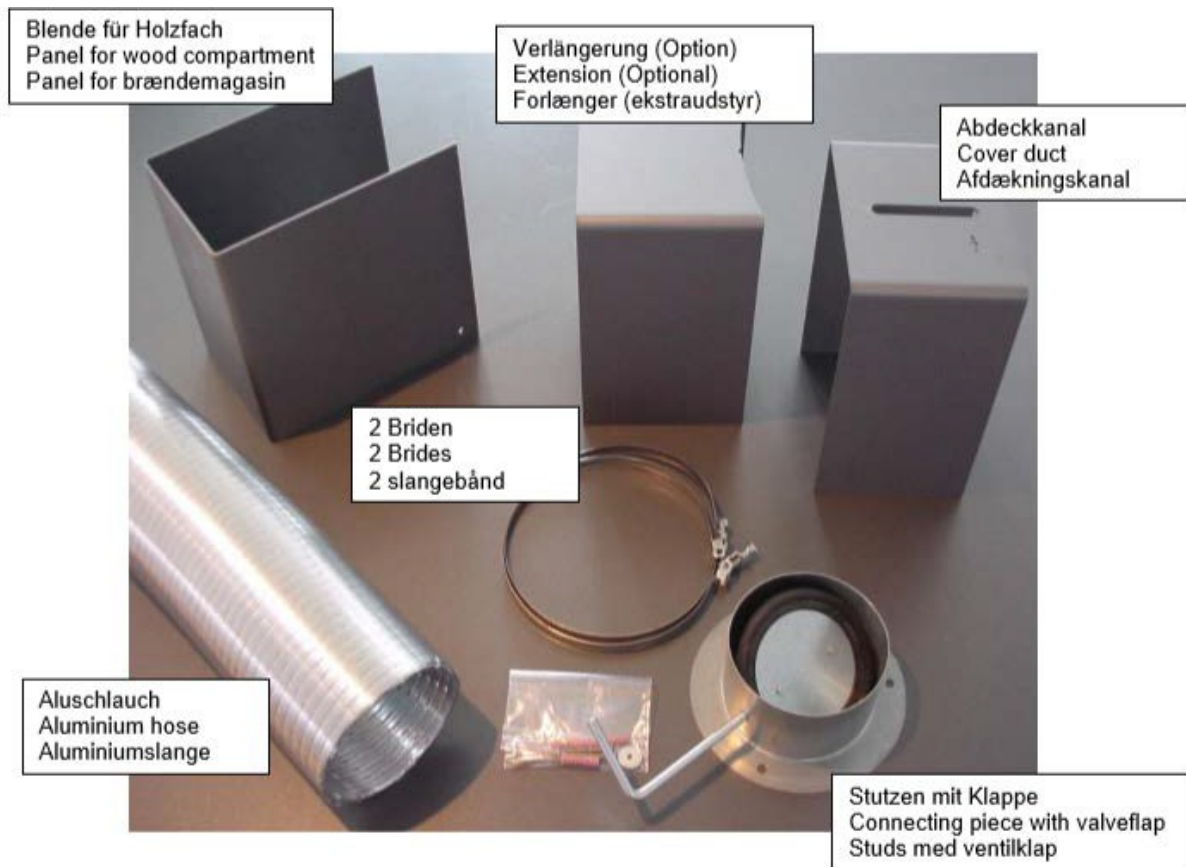

- Fix the connecting piece to the wall using the screws and raw plugs provided. Please note the connection height in relation to the stove.



- Knock the pre-laser-cut opening for the aluminium hose cut with a hammer (Casing and stove body).



- Attach the aluminium hose to the air inlet of the stove using the bride provided and guide the aluminium hose through the designated opening.
- The stove can now be permanently positioned.
- With the second bride, the aluminium hose can be secured to the connecting



- If necessary, break the cover duct at the pre-determined breaking points for the skirting and base plate of the stove.
- First adjust the extension (optional) and then the cover duct above the aluminium hose.

5.2.1.2 Floor option

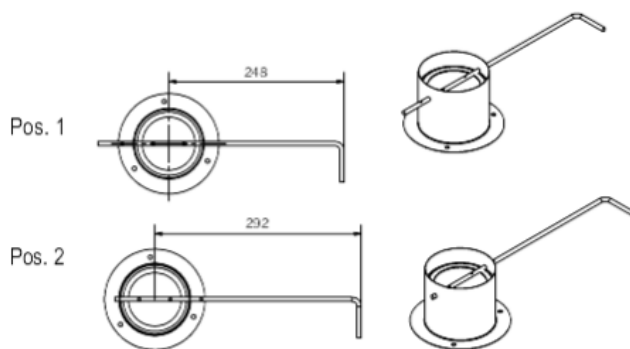
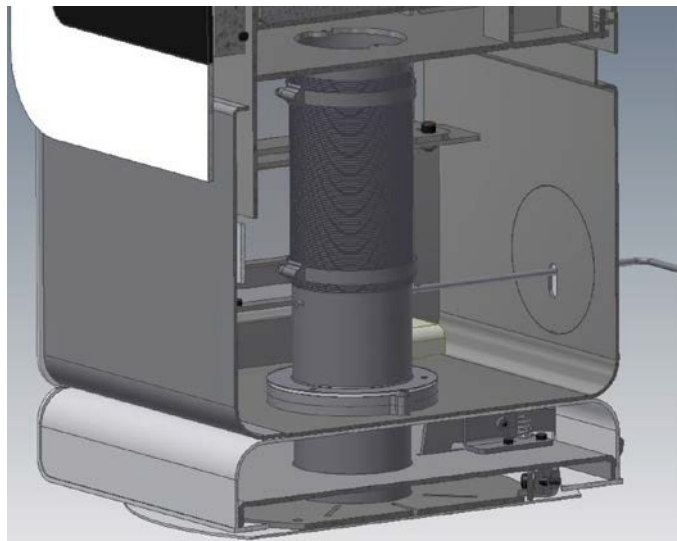

- Adjust the operating lever of the connecting piece in accordance with the table and depending on the stove model.



- Attach the adhesive ring to the connecting piece.

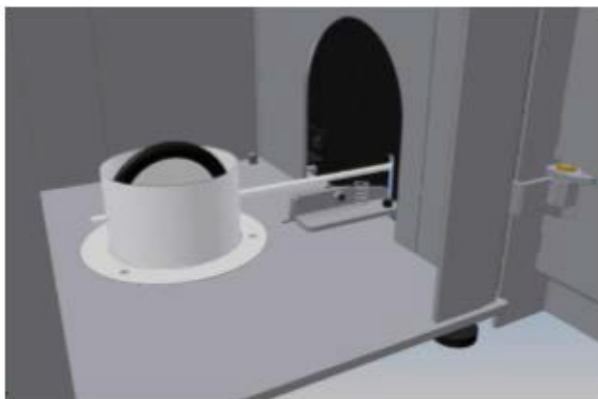

- Before you permanently attach the connecting piece in the specified position, check that it is a perfect fit.
- Securely fix the connecting piece and check that it functions correctly.



- **CAUTION:** Once stuck on, removing the connecting piece will damage the adhesive ring.
- Using the aluminium hose and the brides provided, connect the air inlet connection of the stove with the connecting piece. Extend the aluminium hose if necessary.

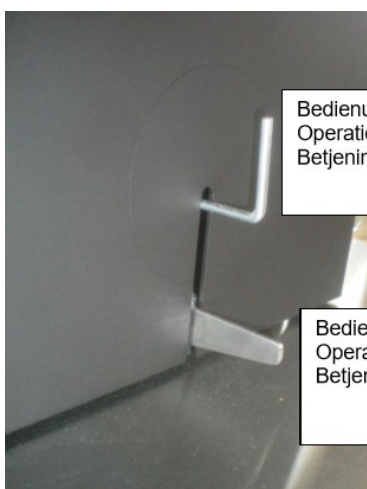

Bedienungshebel Frischluftklappe
 Operation lever fresh air valvelflap
 Betjeningshåndtag frisk luft ventilklap

Bedienungshebel Drehkonsole (Option)
 Operation lever turning table (Optional)
 Betjeningshåndtag drejefod (ekstraudstyr)

5.3 Installation distance in case of combustible walls

The clearance distances (see below 5.3.1; 5.3.2; 5.3.3 and 5.3.4) are tested with soft wood and apply to the Australian test with hard wood. The clearance test refers to combustible materials.

The hearth should be able to accommodate the weight of the stove. The weight of the stove is indicated in the brochure.

The clearance distance from combustible material beneath surrounding or upon the hearth and wall adjacent to the hearth should comply with the guidance of the New Zealand and Australian Standard AS/NZS 2918:2001 Appendix B.

5.3.1 Clearance Distance – Parallel Position / bionic fire fixed

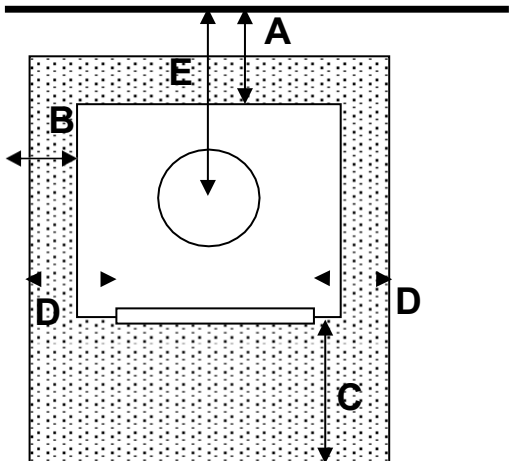
Clearance Distances: Parallel Position	Position	Clearance (mm)
	(A) Rear	100
	(B) Side	250
	(C) Floor protector (front)	300
	(D) Floor protector (side)	200
	(E) Flue (rear)	306

5.3.2 Clearance Distances – Corner Position / bionic fire fixed

Clearance Distances: Corner Position	Position	Clearance (mm)
	(F) Side	120
	(G) Side	120
	(H) Floor protector (front)	300
	(I) Floor protector (side)	200
	(J) Flue (rear)	420

* Note that this temperature passed within the laboratories margin of uncertainty.

Technical Note: No flue shield is required!

1. The clearance measurement A, B, F and J were taken from the distance between walls and closest point of the appliance, C and H was measured from the front of the fuel-loading opening to the edge of the floor protector, D and I was measured from each side of fuel-loading opening, E and J were calculated from the flue's centre to the rear wall.
2. The flue was installed onto the flue spigot, extended centrally and vertically without bend before and after penetration of the ceiling plane.
3. Drawings shown above are not to scale.

5.3.3 Clearance distances bionic fire with swivel

5.3.3.1 Wall position:

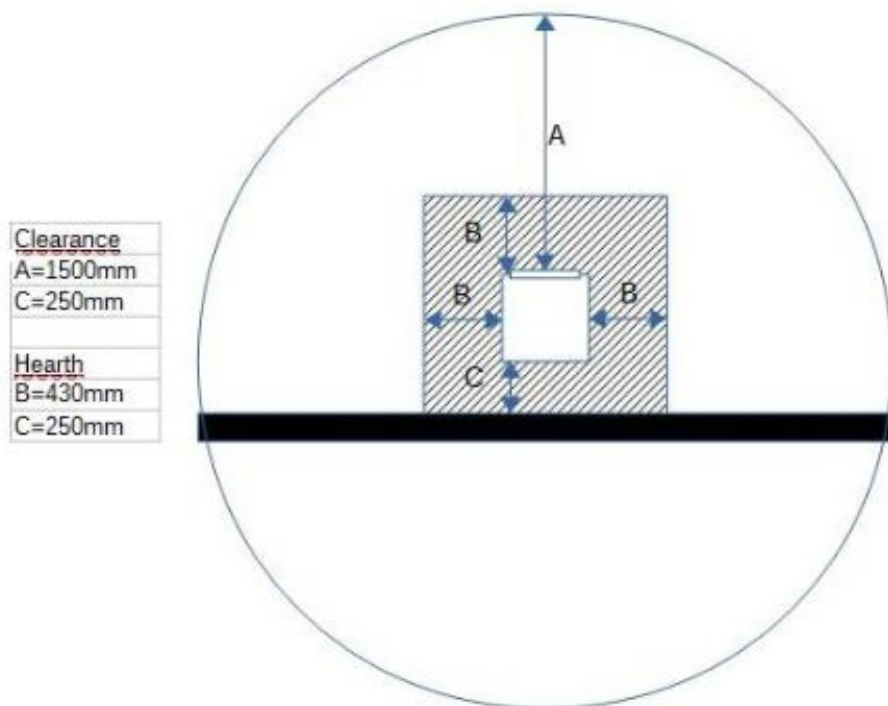

5.3.3.2 Middle of the room position:

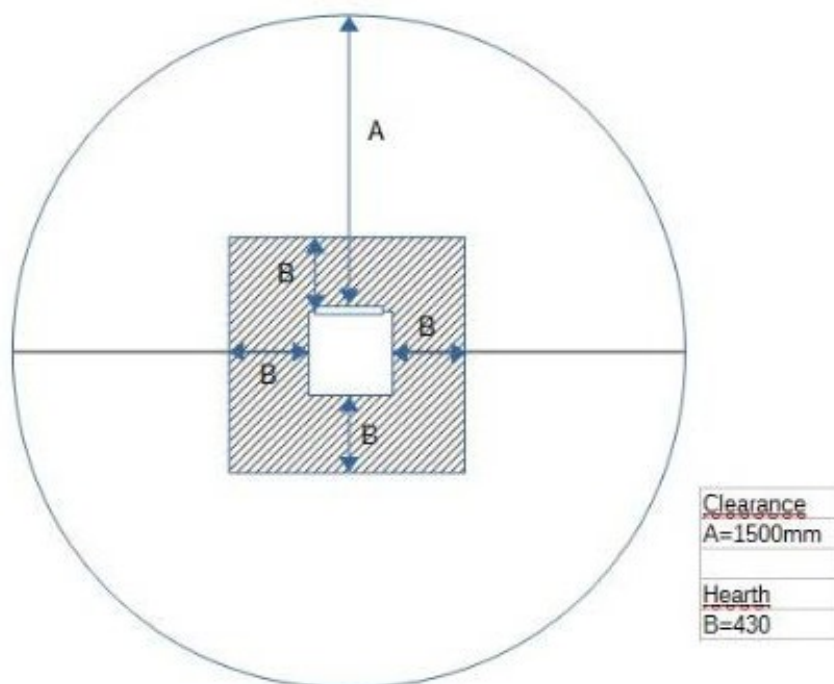

5.3.4 Bionic fire Studio Clearance distances

5.3.4.1 Wall position

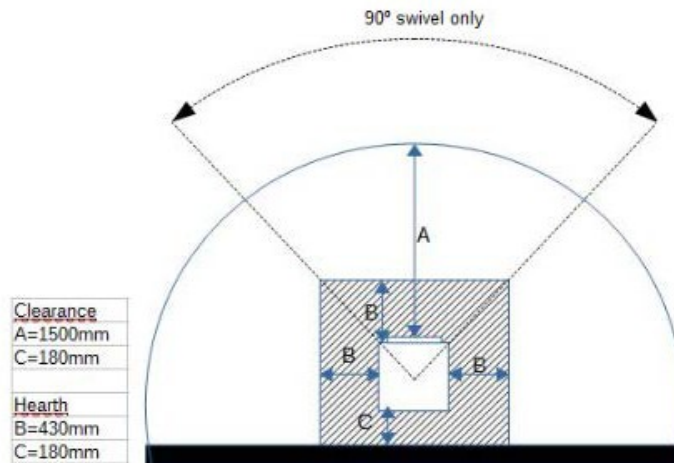

5.3.4.2 Corner position

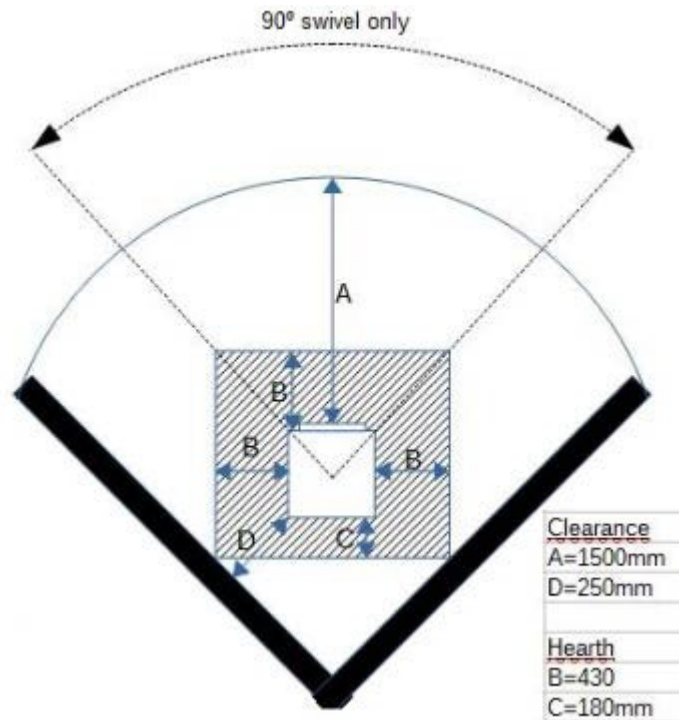

5.4 Stoppers for bionic fire with swivel

With every delivery of bionic fire with swivel there are stoppers supplied to avoid turning the glass door accidentally again a wall to prevent fire hazards. The installer can set these stoppers individually and regarding the circumstances the bionic fire with swivel is installed.

Stopper

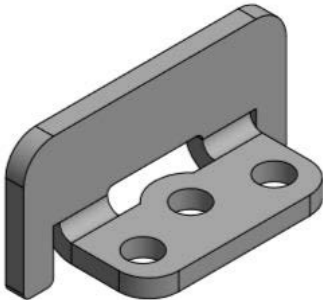

Installation of stoppers

ITEM	QTY	PART NUMBER	TITLE
1	5	8501508	Support bracket
2	5	0110-8x16/M6 PB	BN1359 Pasbolt m/indv 6kt
3	5	0110-M8 skive plan	BN715 Plan skive eltzink
4	10	0710-4eje 608-zz	LE:JE 608-ZZ
5	5	0110-1/4 SKIVE ELZ	BN30710 Udstanstet jernskive
6	1	8511504SV	Bottom plate NZ - welded
7	2	8511514	Stopper
8	2	0110-M5x8 CYL RÅ	BN7 Cylinderskr m/indv 6kt

Note: The bionic fire Studio does not need stoppers because it swivels only 90 degrees.

6 Installation of the chimney

The chimney is the driving force which makes the stove function. In order for the stove to perform satisfactorily the chimney height must be sufficient to ensure the correct draught of 14 to 18 Pa so, as to clear the products of combustion and prevent problems of smoke emanating into the room when firing.

A chimney height of not less than 4.2 meters measured vertically from the outlet of the stove to the top of the chimney should be satisfactory. Any custom chimney flue must be designed and fabricated to provide sufficient draught.

The outlet from the chimney should be above the roof of the building in accordance with the provisions of Building Regulations.

If installation is into an existing chimney, then it must be sound and have no cracks or other faults which might allow fumes into the house. Older properties, especially, may have chimney faults or the cross section may be too large i.e. more than 230 mm x 230 mm. Remedial action should be taken, if required, seeking expert advice, if necessary. If it is found necessary to line the chimney, then a flue liner suitable for solid fuel must be used in accordance with Building Regulation's.

Any existing chimney must be clear of obstruction and have been swept clean immediately before installation of the stove. If the stove is fitted in place of an open fire then the chimney should be swept one month after installation to clear any soot falls which may have occurred due to the difference in combustion between the stove and the open fire.

If there is no existing chimney then either a prefabricated block chimney in accordance with Building Regulations or a twin walled insulated stainless-steel flue can be used following Building guidelines. These chimneys must be fitted in accordance with the manufacturer's instructions and Building Regulations.

A single wall metal fluepipe is suitable for connecting the stove to the chimney but is not suitable for using for the complete chimney. The chimney and connecting fluepipe must have a minimum diameter of 125 mm. Any bend in the chimney or connecting fluepipe should not exceed 45°. 90° bends should not be used. Any bend in the chimney or connecting flue pipe can be 45 or 90 degrees. No more than 2 bends in the entire flue system should be used.

Combustible material should not be located where the heat dissipating through the walls of fireplaces or flues could ignite it. Therefore, when installing the stove in the presence of combustible materials due account must be taken of the guidance on the separation of combustible material given in Building Regulations and also in this stove instruction.

If it is found that there is excessive draught in the chimney, then either an adjustable flue damper or alternatively a draught stabilizer should be fitted. The adjustable flue damper should not close off the flue entirely but should in its closed position leave a minimum continuous opening free area of at least 20 % of the total cross-sectional area of the flue or fluepipe.

Adequate provision e.g. easily accessible soot door or doors must be provided for sweeping the chimney and connecting fluepipe.

You should also familiarize yourself with the draught conditions for chimneys with 2 flues. The flue outlet spigot is either 150 mm (6") in diameter.

For strong draughts, the chimney or flue should be fitted with a draught stabilizer. In which case, it is important to ensure that there is a free flow-through area of mini-mum 20 cm² when the regulating gate is shut. Otherwise, the fuel energy may not be used optimally. If, at any time, you are unsure about the condition of the chimney, you should contact a chimney sweep.

Remember that access to the access door should be kept clear.

6.1 Summary flue installation:

1. The chimney flue must have a diameter of 150 mm
2. Single wall chimney flue until the first ceiling or roof
3. The national building code applies through the ceiling roof
4. Any available chimney flue kit can be used in New Zealand and Australia
5. The **chimney flue of a bionic fire does not require any flue shield** because the chimney flue only gets warm and not hot.
6. Passive house or air tight houses using the external air kit, the required flue system must be an eco or energy saver flue.

Recommendation for installers:

- **Due to the relative low chimney flue temperature (losing only 3 – 4 % of the total energy in the chimney flue) please triple wall the flue above the roof line to the cowl!**
- **For 'eco' or energy save flue please triple wall the flue above the air intake to the cowl!**

6.1.1 General drawing for the chimney installation

ROOF FLASHING & SEISMIC RESTRAINT DETAILS

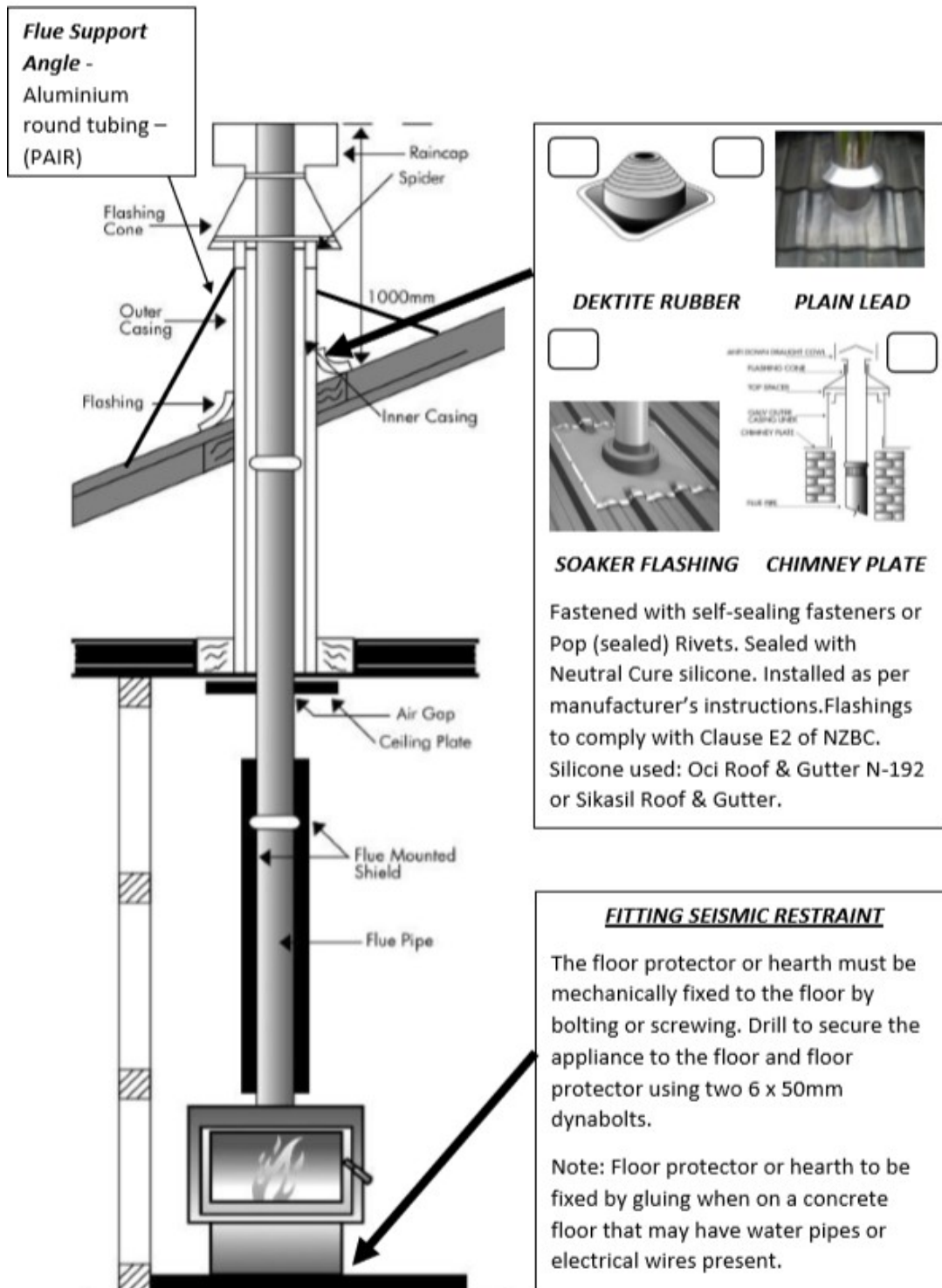

6.2 General instruction for installers

Finally, before firing the stove the first time a check should be made to ensure that the assembly and stove installation has been satisfactory and that there are no leaks in any seals in the appliance and appliance connections to the chimney.

Ensure that the appliance and the chimney flue are functioning correctly before finally handing over to the user. If necessary read the later parts of this manual for guidance on care required when first lighting.

Inform the user that the appliance has been commissioned and ready to use and give instruction on the safe operation of the stove.

These instructions must be left with the user and the user should be instructed to keep them in a safe place

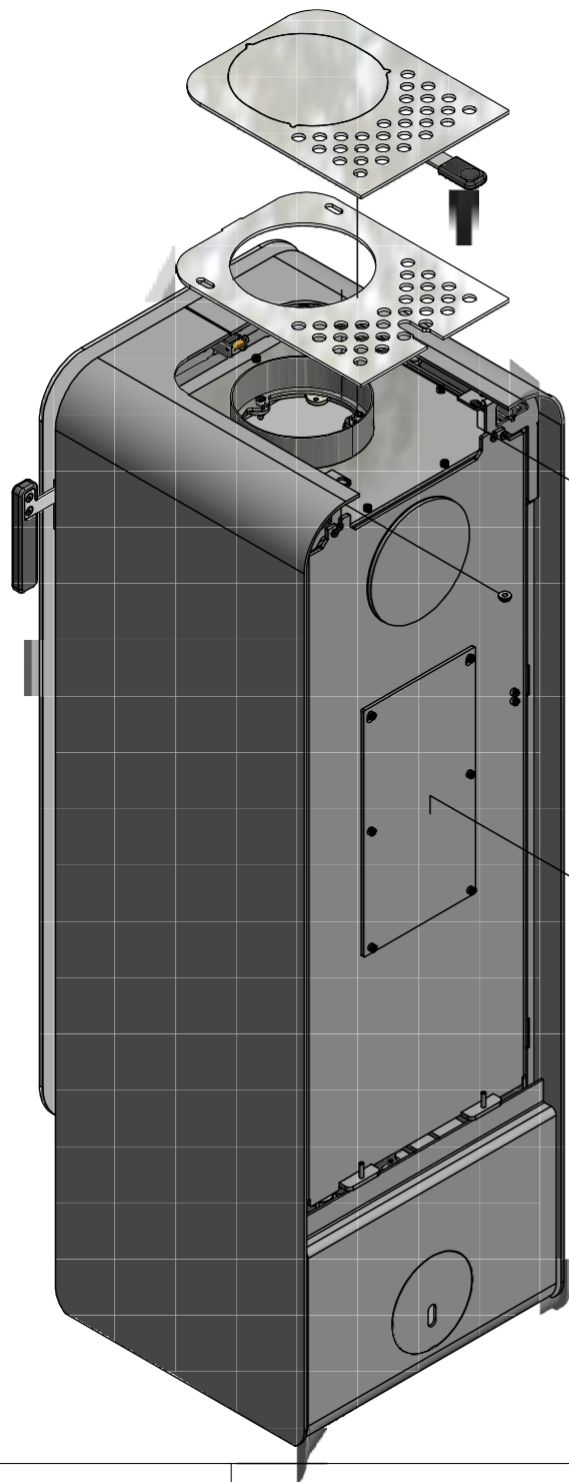

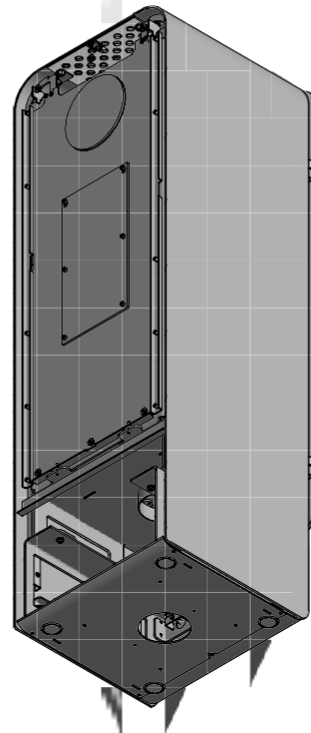

Unscrew the two M6 nuts.

Remove the back plate by lifting it up and off, to access the nuts for the stainless top plate.

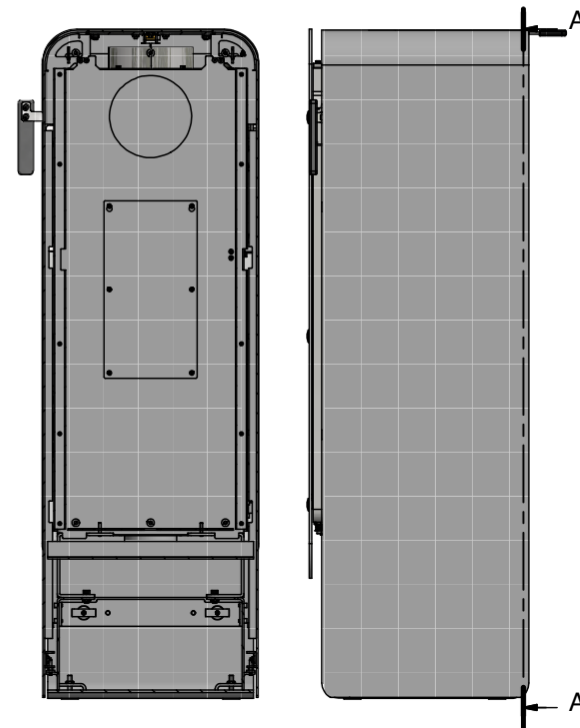

A-A (0,1)



 RAIS [®] ART OF FIRE INDUSTRIVEJ 20, 9900 FREDERIKSHAVN, DENMARK Phone +45 98 47 90 33 - Fax +45 98 47 92 91 E-mail: info@rais.dk - Homepage: www.rais.dk	Designer:	Project manager:	Approved:
	ksj		
	D	M	Y
Corrections:			
Drawing name: Mounting instruction - Removing the top plate			
Project:	Established:	Format:	Revision:
Bionicfire	30-04-2018	A3	
Drawing no.:			8518602

6.3 Operating instructions

Please note that the appliance warranty only covers the use of dry seasoned wood logs on this appliance. The warranty does not cover the use of other fuels either alone or mixed with the wood logs nor does it cover instructions for the use of other fuels.

6.3.1 Fuel

The stove is designed and approved in accordance with AS/NZS 4012/4013 and AS/NZS 2918-2001 Appendix B for stocking with dried firewood. The firewood must have a water content of 15 – 22 % and its maximum length should be the width of the combustion chamber minus 50 – 60 mm.

Stocking with wet firewood causes both soot and environmental pollution and is bad fuel economy. Freshly cut wood contains approx. 50 – 70 % water and is thoroughly unsuitable for stocking.

Count minimum of 1 year of storage time for newly cut wood before using.

Wood with a diameter of no more than 100 mm should be split. Regardless of wood size, it should always have at least one surface area free of bark.

The following fuels are prohibited and **must not** be used: Painted, laminated or treated (impregnated) wood, wood with a synthetic surface, painted refuse wood, chipboard, plywood, domestic waste, paper briquettes and pit coal, as this will produce malodorous smoke, which could be poisonous. The use of such fuels may damage the appliance and will void the warranty.

When firing with the above-mentioned items and the amounts larger than those recommended, the stove is subjected to a larger amount of heat, which results in a higher chimney temperature and lower efficiency. This can result in the stove and chimney becoming damaged and would void the warranty.

The calorific value of the fire wood is closely connected to the moisture level of the firewood. Moist firewood has a low heat value. The more water the wood contains the more energy it takes this water to vaporize resulting in energy is being lost.

6.3.2 Drying and storage

Drying wood takes time. Proper air drying takes approx. 2 years.

Here some tips:

- Store the wood sawn, split and stacked in an airy, sunny place, which is protected against rain.
- Store firewood stacks at a hand's breadth apart as this ensures that the air flowing through takes the moisture with it.
- It is a good idea to bring the firewood into the house 2 – 3 days before you need it.

6.3.3 Room ventilation and stoves

There must not be an extractor fan fitted in the same room as the stove or it should be at least 3 - 4 m away from the bionic fire (very strong kitchen extractor fans). This can cause the stove to emit smoke and fumes into the room.

The stove requires a permanent and adequate air supply in order for it to operate safely and efficiently.

In accordance with the current building regulation the installer may have fitted a permanent air supply vent into the room in which the stove is installed to provide combustion air. This air vents should not under any circumstance be shut off or sealed.

6.3.4 Practical Tips for use of the bionic fire

Lighting the fire

1. Put two large logs in the upper combustion chamber (no wood in the lower chamber)
2. Keeping the bionic fire door open there is a hinge under the steel frame at the bottom of the glass door. You can flap out this hinge and lean it behind the steel nob on the bionic fire.
3. Put a piece of fire lighter on top of the larger logs
4. Put three or four kindling wood over the top of the fire lighter
5. Ignite the fire lighter and lean the door on to the latch for about 5 minutes (until the fire is well established)
6. Shut the door (please also have a look on the video on my website (www.envirosolve.co.nz))

After about 20 minutes or the kindling wood has been burned down.

1. Open the door and keep it for about 2 - 3 seconds until you open the door fully
2. Put another large log on it and shut the door.

After 30 – 40 minutes the bionic fire is switching fully automatically over to down draft mode.

Reloading:

Please only reload when you have only little flames or embers.

1. Open the door and keep it for 2– 3 seconds before you fully open the door. As soon you turn the handle of the door, the down draft will stop (safety reason).
2. Reload one or two large logs on. Please use the glove provided because the fire is very, very hot.
3. Let the door shut. The bionic fire will return fully automatic to the down draft mode.

1



2



3



4



5



6



7



8



Maintaining the bionic fire.

Please always use dry wood!!! If the wood is not quite dry enough, the corners of the glass can go black but that can happen and it is not a problem to clean.

Cleaning the glass:

You can clean the glass with pieces of paper, make them wet with water and put the wet paper into the ash. Use this “ash paste’ on the glass and it will clean the glass.

Or

Get an oven cleaner, spray the glass, wait for 5 minutes, take a wet cloth and clean.

Removing ash

Every bionic fire has an ash pan. Please make sure that the ash in the upper combustion chamber is not going to build up higher than the steel dome in the upper combustion chamber and the three spacers are not getting blocked with ash.

You can remove the upper ash by pushing it through the hole into the ash pan in lower combustion chamber. Any remaining ash can be removed with a vacuum cleaner.

6.4 Stove functioning

The stove has 2 combustion chambers:

- The upper combustion chamber (UCC) is for kindling and re-fuelling
- The lower combustion chamber (LCC) is for the post-combustion and **must not** be used for kindling and re-fuelling.

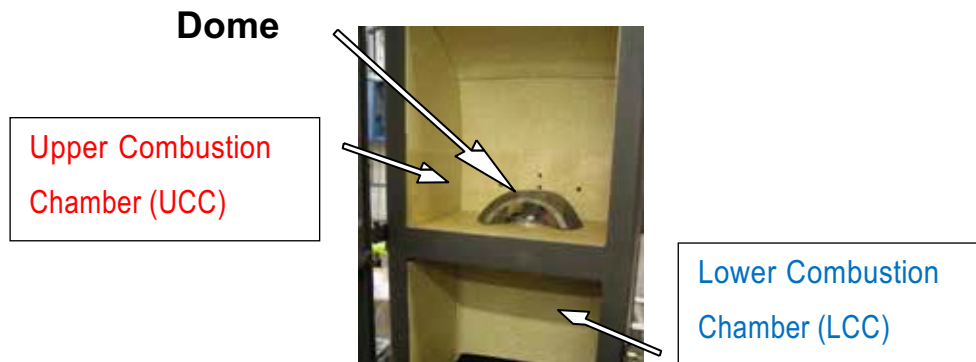

A post-combustion chamber provides a good use of fuel energy and an almost complete combustion of the toxic and harmful substances from the smoke.

Upon lighting the air flows through the UCC and to the flue pipe (chimney). When the stove reaches a certain temperature the air flow is diverted and the still unburned gasses are lead from the UCC through an opening in the bottom stone plate to the LCC. There is a steel dome through which flames are lead through the opening to the LCC for post-combustion of the gasses.

6.4.1 Automatic regulation for combustion air

The stove is equipped with an independent and self-regulating air damper. Hence there is no damper handle.

The primary air is added to the primary combustion zone, i.e. the bed of glowing embers. The cold air is only used in the lighting stage.

Secondary air is added in the gas combustion zone, i.e. air which contributes to the combustion of the pyrolysis gasses (preheated air, which is used for the cleaner glass system and the combustion). This is air sucked through the damper and is pre-heated through the side channels and then emitted as hot scavenging air onto the glass. The hot air rinses the glass and keeps it soot free.

A clean combustion is indicated by clear yellow flames.

The pilot nozzles are placed in the back plate of the upper combustion chamber. They ensure that the bed of glowing embers is fed with air and therefore holds a high temperature. It provides a quick start when re-fuelling and reduces the risk of fire going out.

Important! - during kindling / refuelling

If an ash pan is use, it **must** be placed
at the bottom on lower combustion chamber.



7. First Use

Important:

Place wood only in the upper combustion chamber. This applies for kindling and re-fuelling.

A careful start pays off. Start with a small fire, so that the wood burning stove can get accustomed to the high temperature. This gives the best start and any damage is avoided.

- Be aware that a strange but harmless odour and smoke concoction may emanate from the surface of the stove, the first time you fire up. This is because the paint and materials need to harden. The odour disappears quickly, but you should check the ventilation and draught, if possible. See also the **important warning notice** below about persistent fumes.
- During this process you must be careful not to touch the painted surfaces. It is recommended that you regularly open and close the door to prevent the door seal from sticking.
- The stove may also produce 'clicking noises' during heating and cooling caused by the large temperature differences with the material is subjected to.
- Never use any type of liquid fuel for kindling or maintaining the fire. There is a danger of explosion.
- The stove gets very hot when in use. Always wear protective gloves when tending the stove.
- If the stove has not been used for a while, follow the steps as if you were using it for the first time

Important Warning Note!

Properly installed, operated and maintained, this appliance will not emit fumes into the dwelling. Occasional fumes from de-ashing and re-fuelling may occur. However, persistent fume emission is potentially dangerous and must not be tolerated. If fume emission does persist the following immediate actions should be taken:

- Open doors and windows to ventilate the room.
- Let the fire out or eject and safely dispose of fuel from the appliance.
- Check for flue or chimney blockage and clean if required.
- Do not attempt to relight the fire until the cause of the fume emission has been identified and corrected. If necessary seek expert advice.

Important Warning Note!

Do not use an aerosol spray on or near the stove when it is alight!

8. Important Safety Advice

When using the stove in situations where children, aged and/or infirm persons are present a fireguard must be used to prevent accidental contact with the stove. The fireguard should be manufactured in accordance with all current local building and safety regulation.

Lighting and fuelling

Note:

- If the air system is connected the valve must be open.
- Loading the stove with larger amounts of wood fuel than is recommended may generate excessive heat. This may also damage the appliance and void the warranty

8.1. Tips before firing up

Open a door or window close to the wood burning stove. If there is a 'storm' in the stove coming from the chimney, it is advisable to place a screwed-up piece of newspaper between the upper baffle plate and the chimney, set the paper on fire and wait until you hear a 'rumbling' noise in the chimney. This means there is definitely a draught in the chimney and avoid smoke in the room.

8.2 'Top-down' Lighting

- Open the door and lock it using the small bracket at the bottom of the door.



- Start by placing 1 piece of split log – approx. 1 kg – at the bottom of the upper combustion chamber (UCC) in front of the dome to the small front glass.
- Place approx. 1.2 kg of dry firewood, split in to kindling sticks behind the log and a couple of alcohol briquettes (fire lighter) or similar.
- Light the fire and close the upper convection plate of the stove.



- Close the door and leave it ajar by tipping the handle.



- When the fire has fully established; close the door completely (approx. 5 – 10 minutes).
- Once the temperature reaches a certain level the damper will divert the smoke. This causes a downward flame form the upper (UCC) to the lower chamber (LCC).
- When the last flames are extinguished and there is a nice layer of embers add 1 – 2 pieces wood (about 1 ½ kg). Place the wood on top of the dome at the rear of the UCC. Close the door completely.

Note!

If the fire has burned down too low (i.e. too small embers) it may take longer for the flames to be diverted to the LCC and thus achieve a cleaner burn.

When firing correctly the smoke out of the chimney should be almost invisible – just a ‘flicker’ in the air is observed.

When re-fuelling, open the door carefully to avoid smoke escaping. Never add wood while there is already burning (flames!) in the stove.

RAIS recommend re-fuelling with 1 – 2 pieces wood (approx. 1 – 1 ½ kg) within 1 ½ hours.

Attention!

Keep an eye on the stove when first establishing a fire. During operation the stove door should always remain shut.

Control

Look for signs that indicate a correct firing in the stove:

- Ash is white
- The walls of the combustion chamber are free of soot
- The wood is sufficiently dry

8.3 Warning!

If the firewood is only burning slowly without flames or is smoking and too little air is added, unburned exhaust gases develop.

Exhaust gases can ignite and explode, leading to damage and possible personal injury.



If there are only a few embers remaining you must light the fire again.

If you just add firewood the fire will not be lit, but unburned exhaust gases will develop.



Here firewood has been added to an ember layer which is too small. The air flow is too small – smoke has been developed.



Avoid heavy smoke – danger of exhaust gas explosion.

In case of very heavy smoke open the door and light the fire again.

8.4 Cleaning and Care

8.4.1 Glass

Most wood stoves use a ceramic glass product which is resistant to heat but requires cleaning periodically to keep its appearance.

Soot or opaque marks can be cleaned easily if the marks are fresh. However, if the glass is left dirty for any length of time the acid from the wood can etch the surface of the glass permanently (wet unseasoned wood, soft wood such as used in the building industry and pallet wood should be avoided).

Only clean when cold.

Use only stove glass cleaners to remove heavy tar / soot deposits. All other marks can normally be removed with a damp cloth, then dry with a clean cloth or newspaper. Do not let the glass dry before applying a dry clean cloth.

With more stubborn marks i.e. opaque areas/frosting, you need to put a small amount of wood ash on a clean damp cloth. If the opaque mark/frosting doesn't come out, contact your dealer for a special stain remover.

8.4.2 Paint finish

The appliance has been coated with a high temperature paint which can last for years. Do not clean with a damp cloth or any cleaning products as they can cause rust or discoloration. Only clean when cold, use a brush with soft bristles or dust with a lint free cloth. Only re-spray when necessary.

8.4.3 Mechanical cleaning

The wood burning stove and the chimney must be serviced by a chimney sweep at least once a year.

8.4.4 Prolonged period of non-use

If the stove is to be left unused for a prolonged period of time, then it should be given a thorough clean to remove ash and unburned fuel residues. To enable a good flow of air through the appliance to reduce condensation and subsequent damage leave the air controls fully open.

Prior to a new heating season we recommend checking that the chimney and smoke gas connector are not blocked.

Cleaning the combustion chamber

1. Gently remove the steel dome
2. Put the ash down the hole and it will fall down into the ash pan in the lower combustion chamber.
3. Remove the ash pan from the lower combustion area and empty it into non-flammable container until it has cooled down. You can dispose the ash with your normal household waste.
4. Put the ash pan back into the lower combustion chamber.

REMEMBER! Never remove all the ashes from the combustion chamber – the wood will burn at its best with a layer of ash of approx. 20 mm.

For an Annual clean:

Gently remove the steel dome and the small front glass (ash stop).

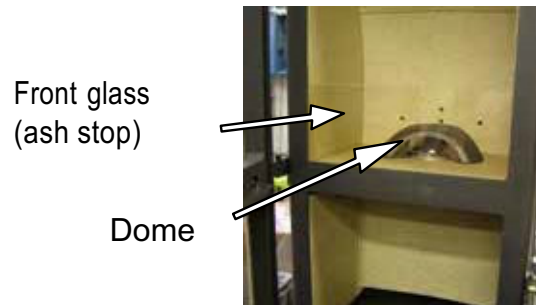

Regarding the cleaning of the upper combustion chamber the ash pan can be used. The pan is placed underneath the UCC in 2 brackets.



The ashes are swept on to the ash pan and disposed of. Replace the ash pan in its position in the lower combustion chamber again.

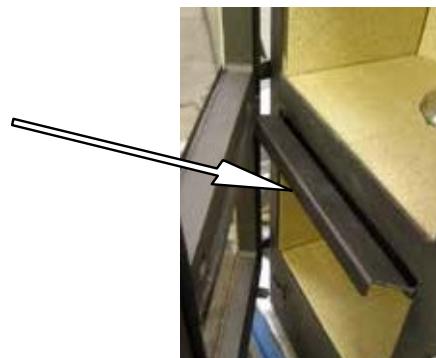

The ash pan must not remain under the upper combustion chamber – this would mean the door cannot be closed and may be damaged.

8.4.5 Cleaning of flue ways

8.4.6.1 Upper combustion chamber (UCC)

In order to access the flue ways gently remove the smoke converter plate (vermiculite) by tilting it to one side and turning it a little slantwise.



Pull out the plate carefully. Remove dirt and dust and the parts in reverse order.

Note! Be careful when replacing the smoke converter plate.

Remove the two screws with an 5 mm Hex key,
then remove the smokechikane

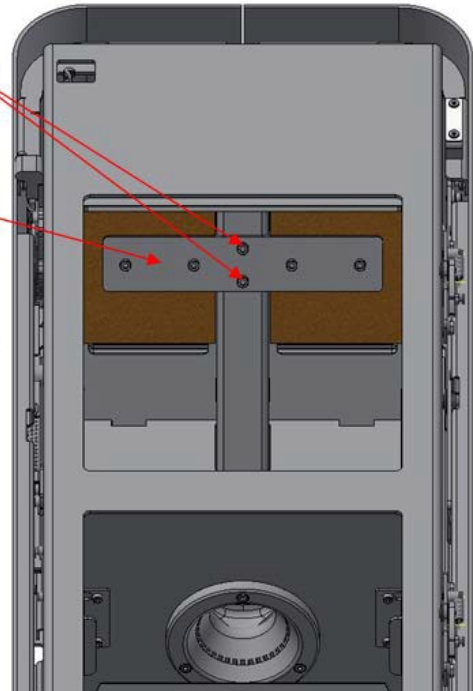
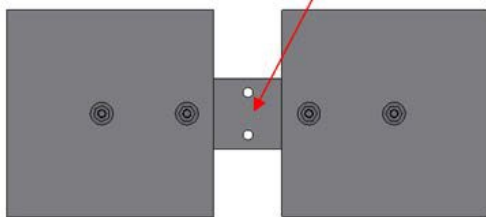

8.4.6.2 Lower combustion chamber (LCC)

The soot from the chimney seat will fall down onto the steel flap above the upper combustion chamber. From there it will down into the smoke channel in the back of the stove. The chimney sweep will vacuum clean the soot out from the back channel of the lower combustion channel.

8.5 Replacing vermiculite panels in the lower combustion



1. One bracket for the ash pan underneath the UCC is removed (use Allen key 4 mm)



2. The bottom plate is gently lifted out of its position with a wide slotted screwdriver



3. The side plate is gently removed.



4. The back plate is gently removed.

! Be careful when replacing the plates.

The appliance must be serviced and maintained using parts approved by the manufacturer, to achieve the proper performance of the appliance.

9. Interruption of operation

9.1 Smoke spillage around the door

It could be due too low draught in the chimney < 12 Pa.

- Check whether the flue or chimney is blocked
- Check whether the extraction hood is switched on. If it is, switch it off and open a window or door in the proximity of the stove for a short while.

9.2 Soot on glass

It could be caused by too wet firewood. Make sure that the stove is heated properly when firing up, prior to closing the door.

9.3 Stove is burning too strong

It could be caused by:

- Leak around the door seal
- Chimney draught is too large > 22 Pa; draught regulator should be installed

9.4 Stove is burning too weakly

It could be caused by:

- Too small amount of firewood
- Too little air supply for room ventilation
- Unclean smoke channels
- Leaky chimney
- Leakage between chimney and flue

If the stove continues to malfunction, we recommend that you contact your RAIS distributor or your chimney sweep.

Warning!

In case of a chimney fire:

- Shut off all air supply from outside (if installed) to the stove
- Contact the fire department
- Never attempt to put out the fire with water!
- Afterwards, you should ask your chimney sweep to check the stove and chimney

Important!

- To ensure safe burning there must be clear yellow flames or clear embers at all times.
- The firewood should not be smouldering.

Appendix

1. Drawings for the spare part

Reservedelstegning / Spare parts / Reservdelsritning / Varosapiitokset
Dessin des pièces de rechange / Tekeningen van reserveonderdelen

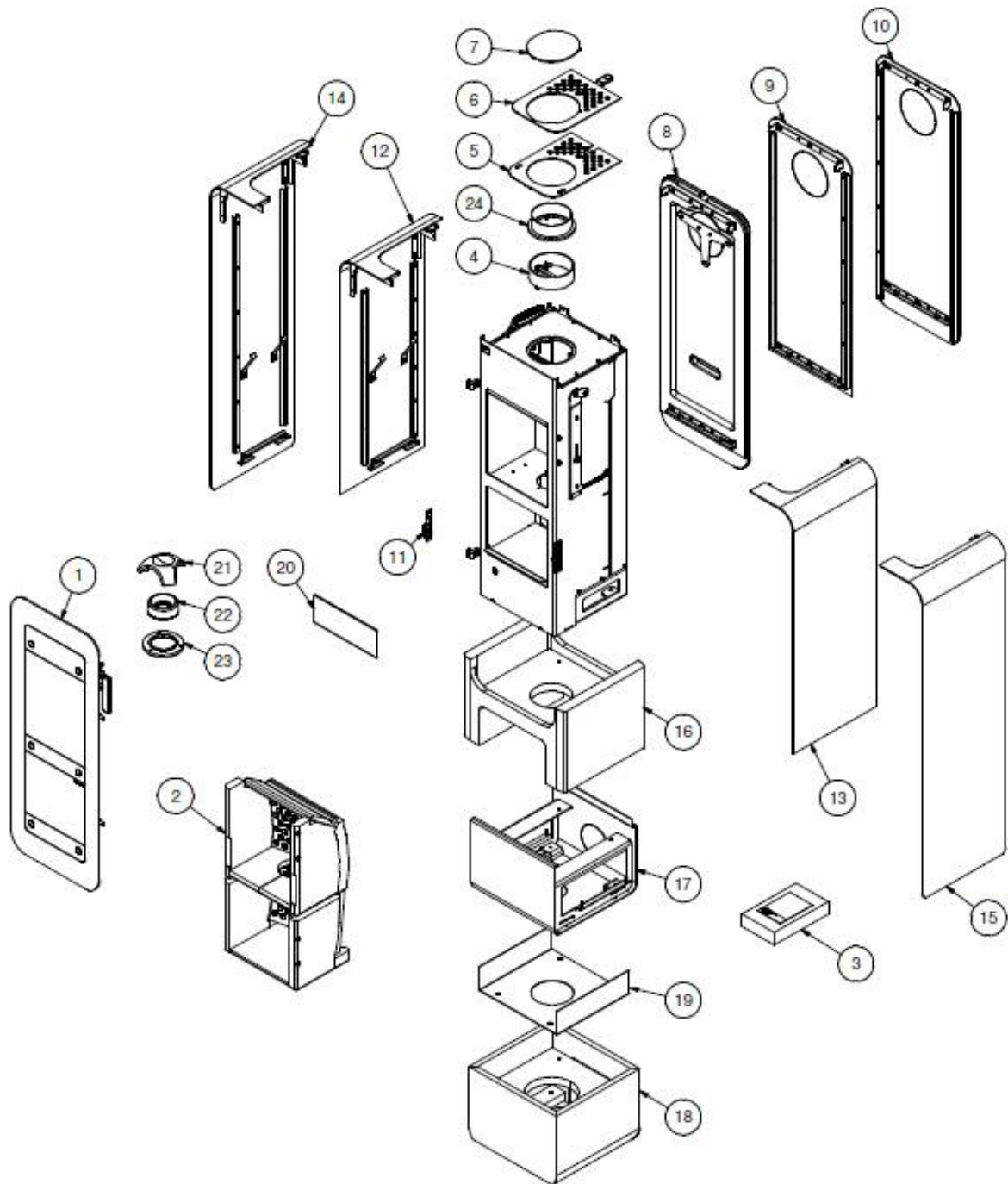

2. Legend for the spare parts

English

RAIS - manual for 

Spare parts

If spare parts other than those recommended by RAIS are used, the warranty is voided.

All replaceable parts can be bought as spare parts from your RAIS distributor.
For reference see spare parts drawing (back of user manual).

Pos.	Quantity	Part no.	Description
1	1	8501090	Glass door
2	1	9502200	Fire brick set
3	1	1015500	Seal set for glass door
4	1	61-00	Flue collar 6"
5	1	8500912SV	Convection bottom plate
6	1	8500911mon	Convection top plate
7	1	8500913	Top outlet cover
8	1	8507010mon	Concrete back panel
9	1	8500127sort	Back panel for steel/wooden socket
10	1	8500107sort	Back panel for concrete socket
11	2	9501890	Closing mechanism
12	1	8500101sort	Side panel left – concrete/wooden socket
13	1	8500102sort	Side panel right – concrete/wooden socket
14	1	8500121sort	Side panel left – steel socket
15	1	8500122sort	Side panel right – steel socket
16	1	8500401	Concrete socket
17	1	8500402sort	Steel socket
18	1	850041190	Wooden socket
19	1	8504101	Reflector plate for wooden socket
20	1	9505010	Stop for ashes (glass)
21	1	9502250	Dome top
22	1	9502251	Dome bottom
23	1	9502252	Flame guard
24	1	61-105	Flue collar 5"
25	1	950133190	Smoke chicane NZ

--

Step 1

4 Technical drawing of the bionic fire Studio

A (0,25)

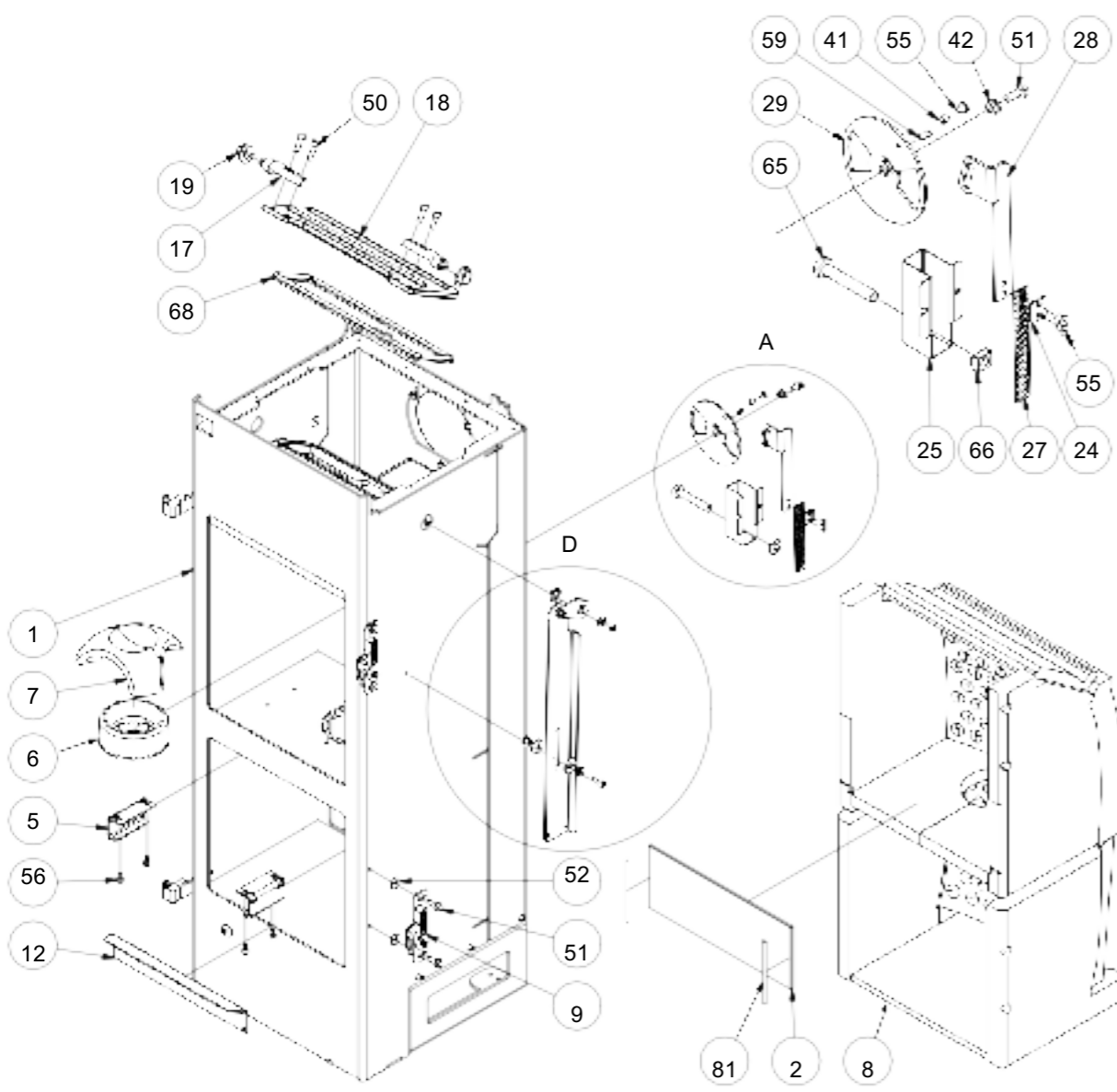

Step 2

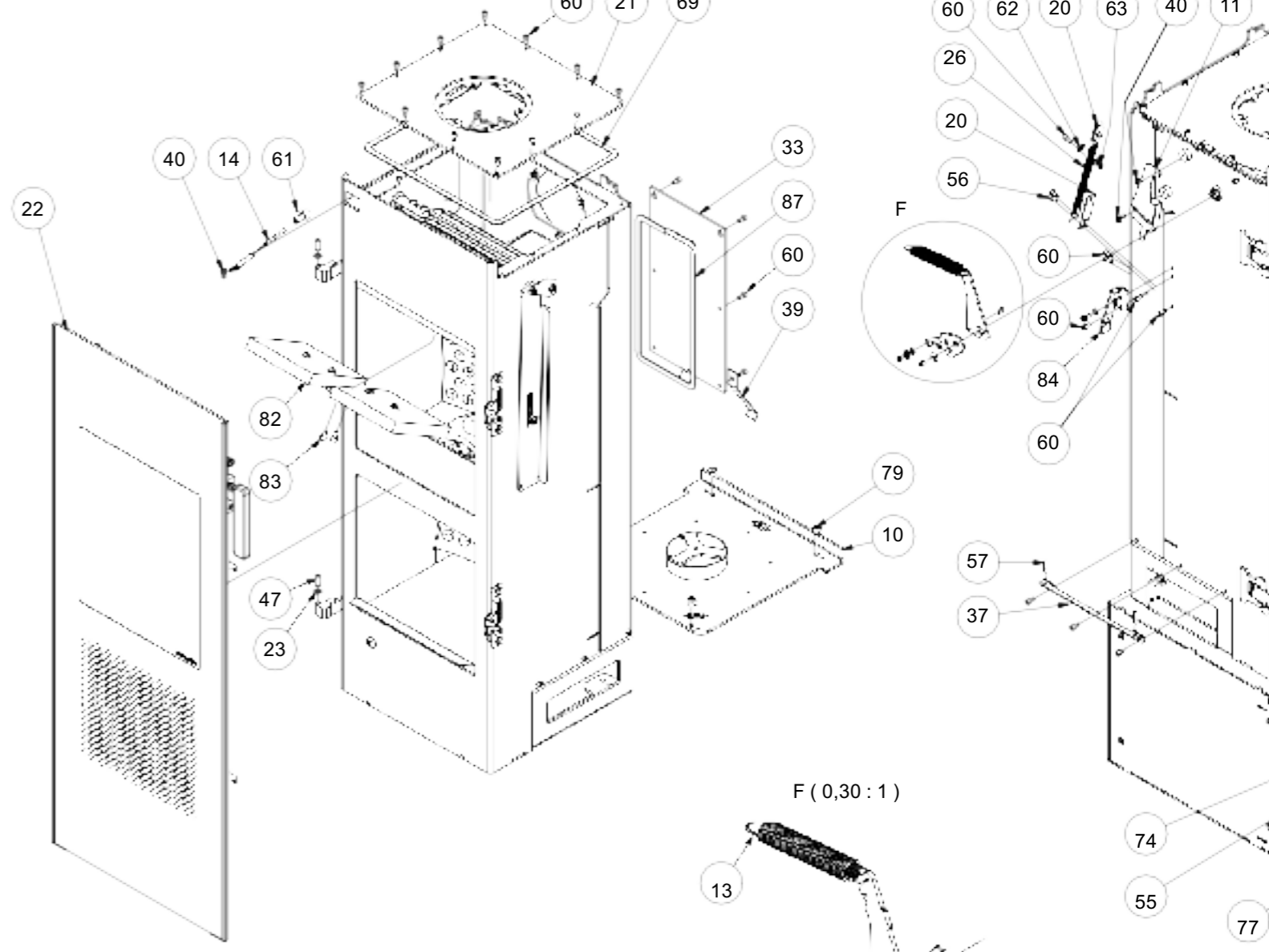

Step 4

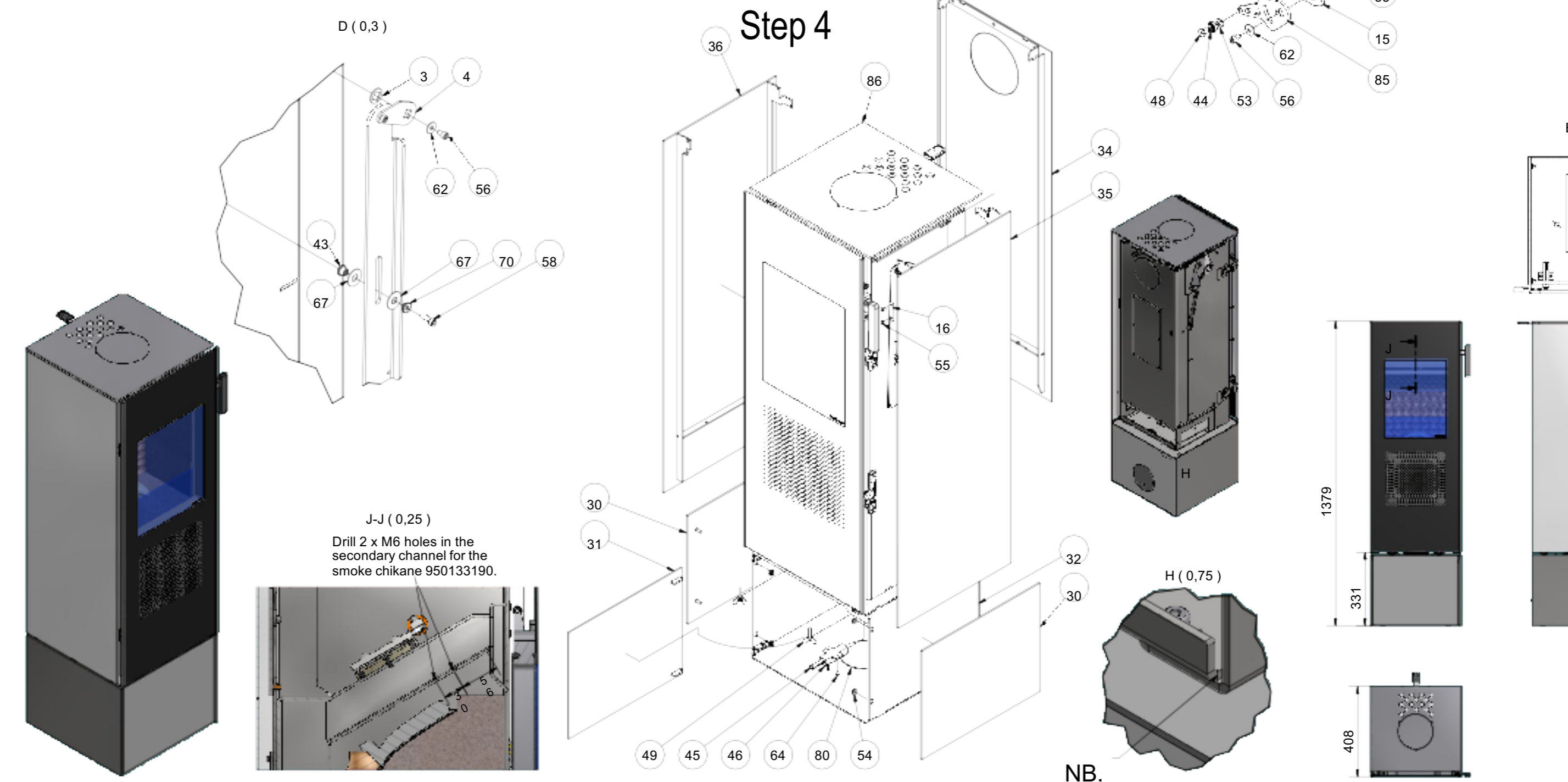

D (0,3)

J-J (0,25)
Drill 2 x M6 holes in the secondary channel for the smoke chikane 950133190.

F (0,30 : 1)

H (0,75)

NB.

1379

331

408

5. Through wall penetration kit

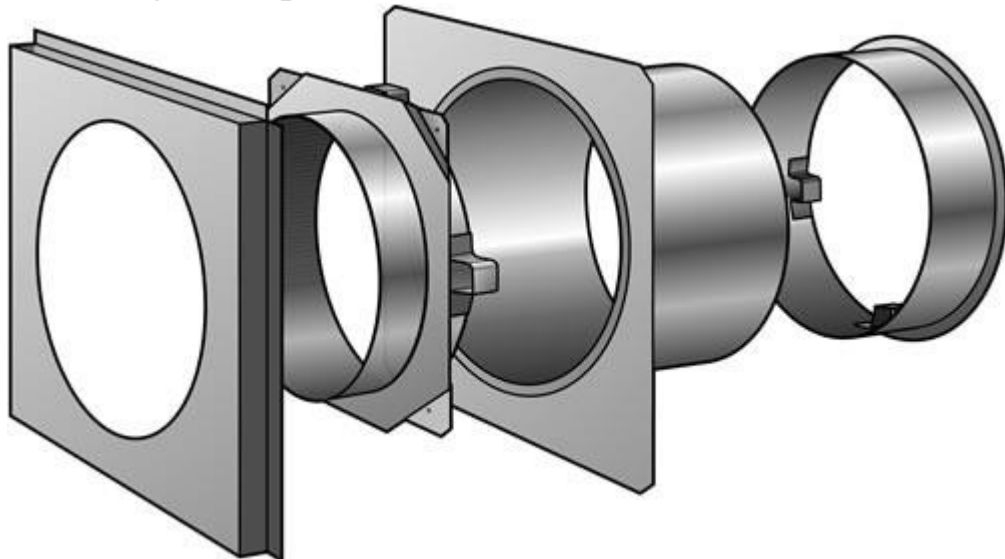

THROUGH WALL PENETRATION KIT

To suit installations using 250mm Outer Casing with Flue Pipe diameters up to 150mm.

For use on tested and untested installations. As per AS/NZS 2918:2001.

It is the responsibility of the installer to ensure that the requirements of New Zealand Building Code's Clause E2 (External Moisture) are complied with.

6. Change of the Chimney Connection

The stove is delivered ready for top outlet, but may be changed to back outlet in the following way:

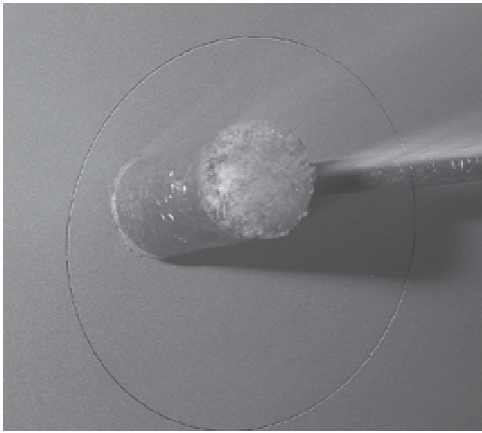

Strike out the knock out plate at the rear of stove.



Remove the blanking plate and the packing, and position them in the hovel at the top. Ensure that the packing is positioned correctly. Screw all elements together with the three M6 nuts.

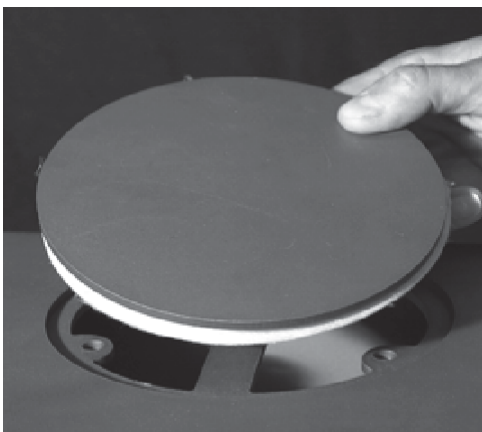

Mount the flue collar (supplied by the dealer) and the clamp for the upper smoke conductor with three M6x20 cylinder screws and M6 nuts.

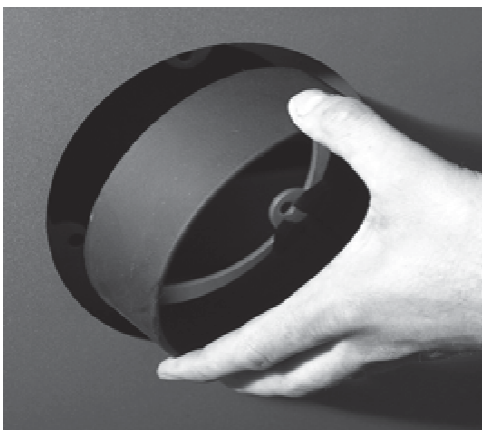

Mount the parts in reverse order.

7. Changing the Vermiculite in the Bionic Fire

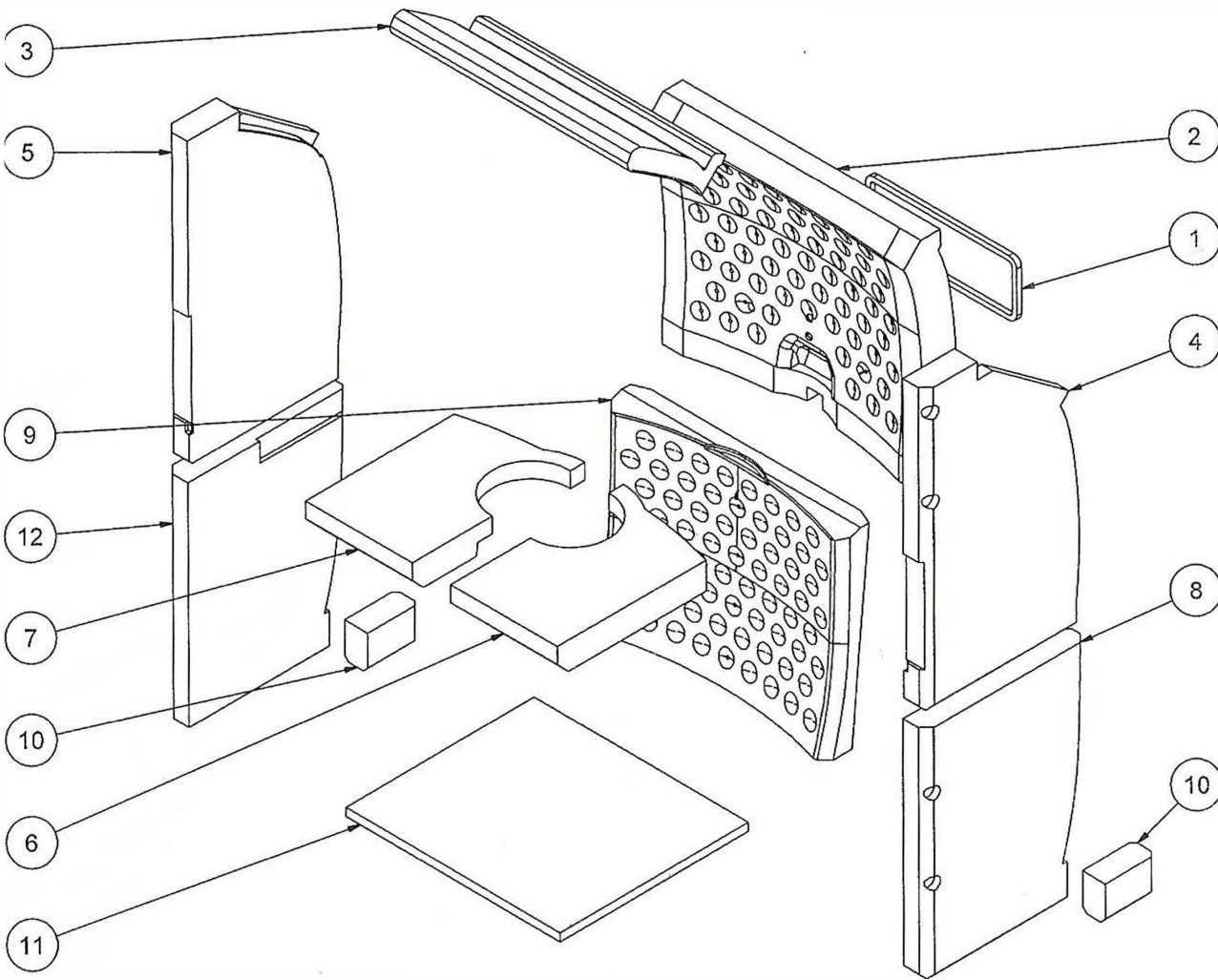

A=&MlfxÜlP" m :ØMBER		N7Ö8²		f OökN8NU	
1	1	0S0 3Y 0U5M	950220t_s05 3lDpt		
2	.	9502201	¶He ¶hDF # BacF pla.e		
3	-	9502202	F re ¶r ck # Baie gla.e		
4	1	9502203	S de stoHe # REGt		
5	1	950220	Söre ¶H k Z Aei süde		
	1	9502205	Botto pCate ¶ Rü'öt		
	u	950220	Bokto plate ¶ Aeī		
0	v	950220	SÄde stoëe - RigCt		
9	1	9502200	Back pçate - BJLtoD		
10	2	9502209	Side s,one - Aeö		
1-	1	9502210	Botto plate		
12	1	95022.2	Süde stone ¶ 9elt		

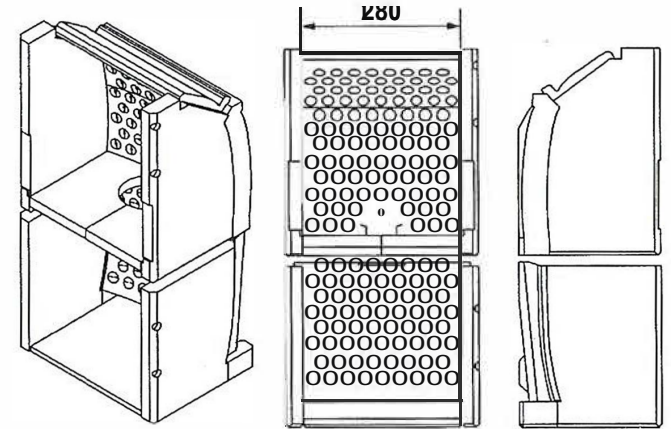

4 M U -ohrect ons
q2-05i20w3 MesL,edeEt added
©öBēn> gKæ>K

†sýgne! <¶GaAt Eana'ero Sprprreç

¶ijtaäcisöed1 O D FJHĒat
x2\$-¶ 2012 ¶ c" ¶ C"

R I
ART .. OF FIRE

¶H0QMOK?SA> &0,)*00 5K212K @N6.TJ, 131G/KA
E+GēeS %0000\$/e äIT 00000%
4 c¶¶ n¶j-¶¶¶ Xa ¶ 7idk7 s

Bend öoöD2
Re alks! ov IN
Materäad1

8\$2
R61.96° 0¶ll¶g noj
Srr2200

¶HARTE ¶R"¶GELGER FOD ¶NE¶EPE MÄL
¶DPR: Cæ & PDEag ¶¶¶ # ¶ h, ¶¶¶
¶¶¶ ¶¶¶ x=¶ u' ¶ y ¶ w ¶ l ¶ x ¶
Ö¶E9-4-E ¶F"¶68:¶ER FÉR ¶:ÆC¶¶E
VRmI0¶D¶¶ ¶k¶¶ ¶lp ¶w z ¶¶¶¶¶ ¶¶¶ ¶N¶h0 ¶Y
> 2 /*C0, ¶E9 - · 5= ¶ ¶ 13 G7A4 H ¶ 6 < ¶# ¶¶
3576E-SE ¼ MM
¶¶¶

0 35 @ 4 9 = \$: AB CD; 162 : ¶E<" 8F G H

8. Fire Box drawings and dimensions

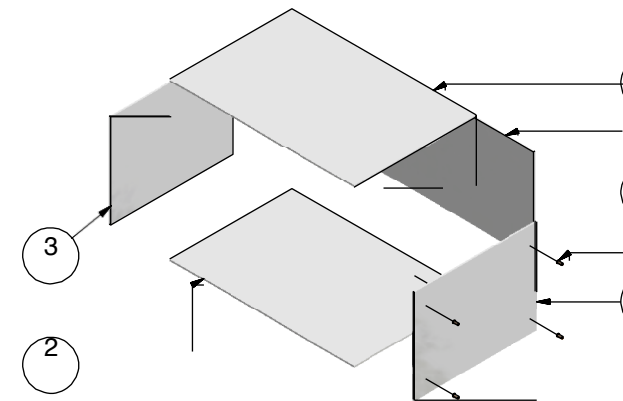
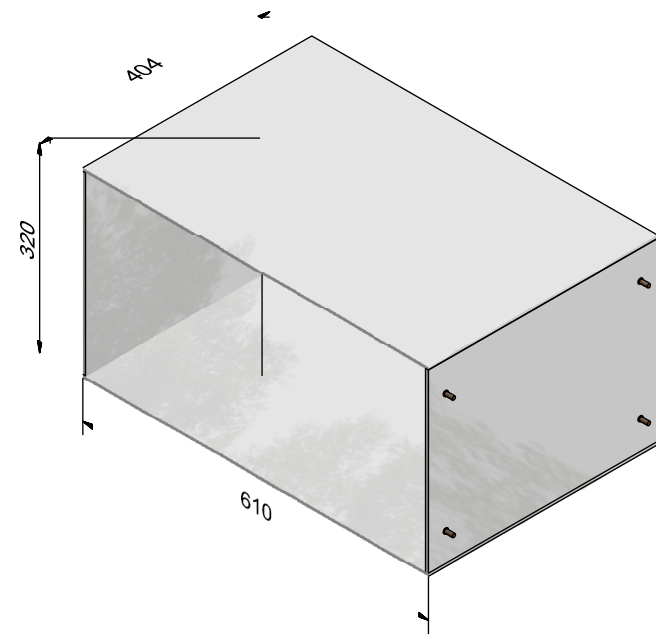
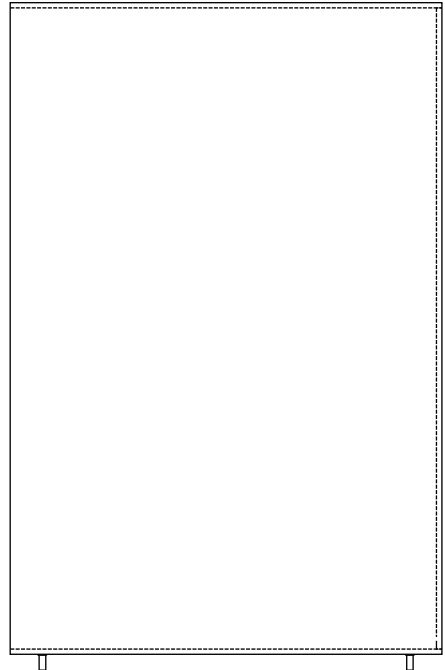
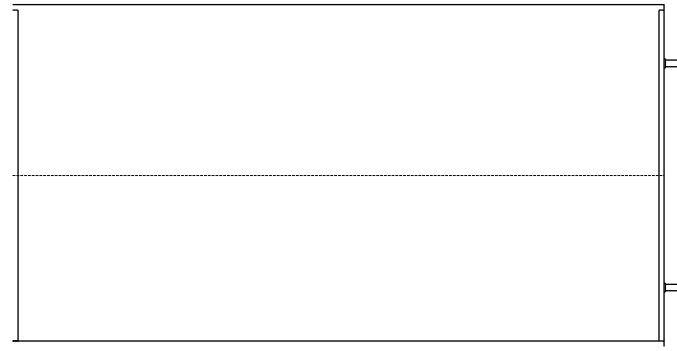
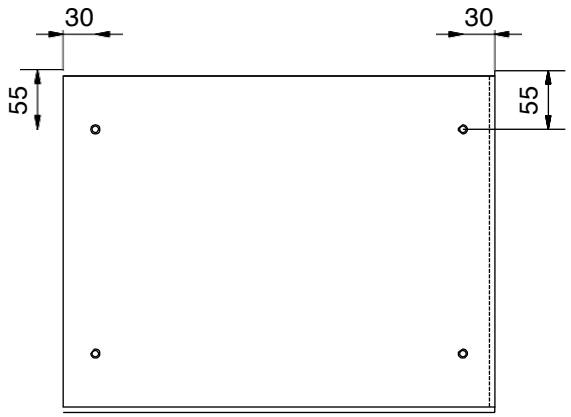

ITEM	QTY	PART NUMBER	TITLE	Thk
1	1	9502401	Backplate	5 x 6
2	2	9502402	Top - Bottom of bench	5 x 6
3	2	9502403	Socket side	5 x 4
		Ø110-M6X15 SV.BOLT	ST.CU. STUDWELDING BOLT	

TILLADTE AFGIVELSER FOR LINEÆRE MÅL	
0.5-3	33.6
0.1	0.01
TILLADTE AFGIVELSER FOR VINKELMÅL	
0-10	10-50
>>400	
AFVIGELSE I MM	
1.8	0.9
0.6	0.3
0.15	

D.M.Y 27- Corrections:
01-2015 Assembly updated

Change order Designer: Project manager:
user ks
Drawing change: Improvement proposal: Established: 30-08-2013

RAIS[®] Bend Tool: ov uv
INDUSTRIVEJ 20, 2900 FREDERIKSBORG, DENMARK
Phone +45 98 47 90 33 - Fax +45 98 47 92 91
E-mail: info@rais.dk - Homepage: www.rais.dk

Remarks:
Material:

Bench

Project: Studio Part of: Revision: A Drawing no.: 9502401S

89. NZ Lab Testing Results Summaries

Unit 1 / 25 Highbrook Drive, East Tamaki, Auckland
Telephone +64 9 271 1616

Thursday, October 26, 2017

RE: Bionic downdraft heater safety test setup.

Client:

Attention: Mr. Rene Haerberli.
Company Name: EnviroSolve Ltd.
Company Address: Ohakune Road, R D 3, Wanganui.
Phone: +64 (06) 385 4871.
Manufacturer: Rais A/S, Industrivej 20, 9900 Frederikshavn Danmark.

Product:

Make: RAIS.
Model: Bionic Fire.
Type: Freestanding – Downdraft.

Technical information:

The RAIS Bionic fire was tested as per AS/NZS 2918:2012 Appendix B, as test enclosure was setup as per AS/NZS 2918:2012 Appendix B(a). The results were reported on Spectrum Laboratories Test Report #0366, dated 12/02/2015.

AS/NZS 2918:2012 Appendix B(a):

B6 TEST ENCLOSURE

Within the test room, the test shall be carried out in a test enclosure complying with the following:

- (a) For a free-standing appliance, the test enclosure shall comprise two vertical side walls forming a corner at an angle of 90 degrees, a horizontal floor forming corners with each of the two side walls, and a horizontal ceiling situated 2.4 ± 0.1 m above the floor to form corners with each of the two side walls. The corners formed between the ceiling and side walls shall be sealed against air flow, and provision shall be made to vary the horizontal positioning of the side walls with respect to the floor and ceiling. The ceiling, walls, and floor shall extend a minimum of 1.20 m beyond the horizontal perimeter of the appliance, and the side walls and ceiling shall be finished matt black over the inward-facing surfaces.

Note:

This letter is to be read with conjunction of Spectrum Laboratories Test Report #0366, dated 12/02/2015.

.....

P. Chen
Authorized Signatory
Spectrum Laboratories Limited



All tests reported herein have been performed in accordance with the laboratory's scope of accreditation



Spectrum Laboratories Ltd is accredited by International Accreditation New Zealand (formerly Telarc). The tests reported herein have been performed in accordance with the terms of our accreditation. This accreditation does not extend to any opinions or any interpretations of test results contained in this report.

(This report is endorsed)

Test Report Number: 0366.

Item Under Test (IUT):

Make: RAIS.
Model: Bionic Fire.
Type: Freestanding.

Client Details:

Attention: Mr. Rene Haeberli
Company Name: EnviroSolve Ltd.
Company Address: Ohakune Road, R D 3, Wanganui
Phone: +64 (0)6 385 4871
Manufacturer: Rais A/S
Industrivej 20, 9900 Frederikshavn, Danmark

Standard Specification:

AS/NZS 2918 2001 Appendix B Thermal testing of installation clearances;
Appendix B sets out the method for determining the maximum temperature rise above ambient temperature of heat sensitive materials as specified installation clearances from a solid fuel burning appliance.

Client Instructions:

The client requested the item be tested to the above standard in both parallel and corner positions.

Sample Details:

The sample supplied was a production model representative of the mass produced version.

Technical Notes:

The appliance was tested at both conventional and down drought modes, it was observed the conventional mode operation yielded higher temperature rises; herein the reported results are with respect to conventional mode operation.

Report Record:

Test Record (Free Standing) CD 10230 revision 1.1.
Report Preformat CD 00264 revision 2.1.

Checked by
Mr. P. Sparrow
Authorized Signatory

Tested by
Mr. P. Chen
Compliance Engineer

Issue Date: 13/02/2015



All tests reported herein have been performed in accordance with the laboratory's scope of accreditation

Test Report: 0366

Accreditation N^o: 962

Section 1: Description

Overall external dimensions:

The heater had the following overall external dimensions.

Height	1252 mm	- measured to the highest point of the heater
Width	403 mm	- measured at the widest points of the heater
Depth	410 mm	- measured from the rear most panel to the glass door

Refer to design drawings for detailed dimensions.

Firebox internal dimensions:

The fire box had the following basic internal dimensions;

Height	295 mm	measured between floor and leading edge of the ceiling baffle.
Width	280 mm	measured between the interior side walls.
Depth	200 mm	measured between the rear interior wall and inner edge of fuel retaining glass.

Refer to design drawings for detailed dimensions.

Removable grilles and cook tops:

The heater did not have any removable grille or cook tops.

Fuel loading doors:

The door consisted of a one piece of a rectangular glass window with round corners.

Overall dimensions of the door were:

Height	1030 mm
Width:	405 mm

The lowest edge of the glass was located 225 mm above the floor.

Refer to design drawings for detailed dimensions.

Refractory materials and gaskets:

The heater contained six vermiculite fire bricks in the upper combustion chamber, four vermiculite bricks in the lower combustion chamber; covering side walls, rear wall, ceiling and floor.

The door frame was fitted with a fire resistant rope to seal the gap between the door and the firebox aperture.

Refer to design drawings for material dimensions and specifications.

Water heating device:

The heater was not fitted with a water heating device.

Air circulation Fan:

This heater was not fitted with an air circulation fan.

Catalytic combustor:

This heater was not fitted with a catalytic combustor.

Bypass damper:

The heater was fitted with a bypass damper to switch between conventional and down drought mode. The bypass damper was controlled automatically.

Refer to design drawings for detailed dimensions.



All tests reported herein have been performed in accordance with the laboratory's scope of accreditation

Test Report: 0366

Accreditation No. 962

Section 2: Air inlets and outlet

Primary air:

The primary air supply entered the heater from the rear of the base and channeled into upper combustion chamber from the metal just below the glass seal, and lower combustion chamber via the opening on the rim located on the ceiling of the lower combustion chamber.

The primary air was uncontrolled

Refer to design drawings for detailed dimensions.

Flue gas outlet:

The flue gas outlet spigot was positioned centrally when viewed from the front of the firebox and the spigot's axial centre was 106 mm from the rear edge of the appliance's top panel.

The flue spigot had an internal diameter of 132 mm.

Refer to design drawings for detailed dimensions.

Cross sectional area:

The flue spigot outlet aperture was calculated to be 13685 mm²

Refer to design drawings for detailed dimensions.

Section 3: Flue System

Flue pipe:

The flue system consisted of a single skin flue pipe setup.

A single 150 mm diameter unpainted stainless steel flue that met the requirements of AS/NZS 2918:2001

Refer to design drawings for detailed dimensions.

Flue shield:

The heater was not fitted with a flue shield.

The heater was not fitted with a deflector.

Ceiling plate

A ceiling plate was fitted during test.

A 0.5 mm thick unpainted stainless steel ceiling plate measuring 345 mm x 345 mm with a central 180 mm circular hole was installed and spaced 11 mm from the ceiling; this allowed for a 6 mm air gap around the edge of the plate. A 15 mm gap was maintained around the circumference of the 150 mm flue pipe.

The ceiling plate and spacers were sourced from Sheet metal Fabricated Products Limited.



All tests reported herein have been performed in accordance with the laboratory's scope of accreditation

Test Report: 0366

Accreditation No. 962

Section 4: Testing Information

Fuel data:

Type of Fuel used:	Soft Wood.
Species of Firewood:	Pinus Radiata.
Largest axis of firebox:	280 mm Left to Right.
Fuel loading axis:	280 mm Left to Right.
Flash fire test fuel pieces:	4 pcs
Flash fire total weight:	1.54 kg
Test Fuel length:	140 168 mm
Moisture content range:	10% 20%
High fire fueling Rate:	1 pcs at 10 minutes interval approx.

Operating condition:

Ambient temperature range during test:	17.4°C to 22.7°C
Barometric pressure:	1008 hPa

Section 5: Test Results and Clearance

Maximum allowable temperature rises (as per AS/NZS 2918:2001)

To comply with the temperature limits of this standard the temperature rise above ambient temperature of monitored surfaces shall not exceed 65°C for the high fire test and 85°C for the flash fire test.

Floor Protector:

AS/NZS 2918 standard section 3.3.2 places minimum requirements for the floor protector.

For an appliance other than a fireplace insert appliance, the floor protector shall extend under the appliance and not less than **300mm** beyond the front of the fuel loading and ash removal openings. The width of the floor protector shall be not less than the width of the appliance and shall extend not less than **200mm** from each side of any ash removal or fuel loading openings unless the floor forms an abutment with a wall or heat shield at a lesser distance.

Minimum Access Clearance:

AS/NZS 2918 standard section 3.2.1 places minimum requirements for the access clearance.

To provide the user with access to the appliance, the clearance between any part of the appliance which only hand access, occasional user access, or maintenance access is necessary and any adjacent fixed surface or object shall be not less than 100 mm.

Floor Protector information:

Floor protector used on test.		
	Material	Thickness(mm)
Base Layer	n/a	n/a



Test Report: 0366

Accreditation No. 962

Test Results for high/Flash fire:

Parallel Position Clearance Distance	Position	Clearance (mm)	Max temp rise (°C)	
			High	Flash
	(A) Rear	100	Rear Wall	
			53.04	59.64
	(B) Side	250	Side Wall	
			61.49	62.77
	(C) Floor protector (front)	300	Floor	
			15.78	17.74
	(D) Floor protector (side)	200	Ceiling	
			23.63	26.01

Corner Position Clearance Distance	Position	Clearance (mm)	Max temp rise (°C)	
			High	Flash
	(F) Side	120	Rear Wall	
			43.12	38.89
	(G) Side	120	Side Wall	
			42.42	39.18
	(H) Floor protector (front)	300	Floor	
			19.08	20.00
	(I) Floor protector (side)	200	Ceiling	
			25.64	23.92

* Note that this temperature passed within the laboratories margin of uncertainty.

Technical Note:

1. The clearance measurement A, B, F and J were taken from the distance between walls and closest point of the appliance, C and H was measured from the front of the fuel loading opening to the edge of the floor protector, D and I was measured from each side of fuel loading opening.
2. The flue was installed onto the flue spigot, extended centrally and vertically without bend before and after penetration of the ceiling plane.
3. Drawings shown above are not to scale.

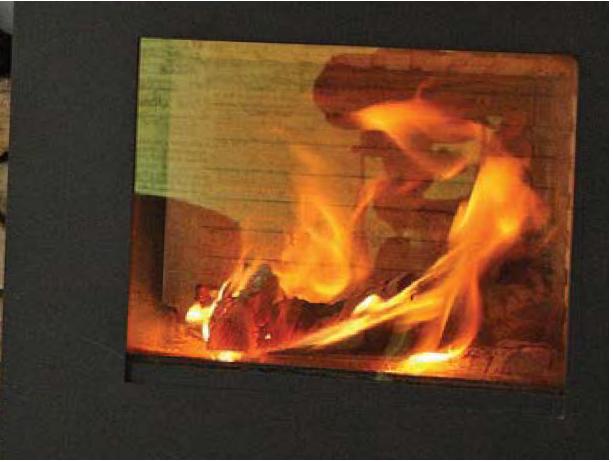

envirosolve

**Your exclusive New Zealand & Australian distributor:
EnviroSolve Ltd.**

Dr. Rene Haeberli, Director
Ohakune Road, RD 3
Raetihi, New Zealand

Email:

rene.haeberli@envirosolve.co.nz

Phone: +64 (0) 6 385 4871

Mobile: +64 (0) 21 24 24 211

Website: www.envirosolve.co.nz

attika[®]
FEUERKULTUR

ATTIKA FEUER AG

Brunnmatt 16
CH-6330 Cham
Switzerland
www.attika.ch

RAIS[®]
ART OF  FIRE

RAIS A/S

Industrivej 20
DK-9900 Frederikshavn Denmark
www.rais.dk