

VIVA L GAS

NZ



attika®
FEUERKULTUR

RAIS®
ART OF FIRE

Manufacturer's plate

Imported by: EnviroSolve Ltd.

Models:

VIVA 100 L Gas / VIVA 100 L G Gas / VIVA 100 L Classic Gas / VIVA 100 L G Classic Gas
VIVA 120 L Gas / VIVA 120 L G Gas / VIVA 120 L Classic Gas / VIVA 120 L G Classic Gas
VIVA 160 L Gas / VIVA 160 L G Gas / VIVA 160 L Classic Gas / VIVA 160 L G Classic Gas

This appliance must be installed in accordance with the rules in force, and only used in a sufficiently ventilated space. Consult instructions before installation and use of this appliance. Tested and Certified for use on Biopropane. Product ID: 0359CS1717
Efficiency class 1

N A T U R A L <input type="checkbox"/>	Burner pressure	1.32 kPa (Hot)
	Supply pressure	2.2 kPa max, 1.8 kPa min
	Gas input rate	33 MJ/h
	Must be used with external regulator set to 2 kPa	
L P G <input type="checkbox"/>	Burner pressure	2.7 kPa (Hot)
	Supply pressure	3.2 kPa max, 2.6 kPa min
	Gas input rate	29 MJ/h



Manufacturer: RAIS A/S, Industrivej 20, 9900 Frederikshavn, Danmark

This stove had been tested and certificated for several countries (see the rating plate). It may be necessary to adjust the stove for safe and correct use in your country/area.

This stove has been tested and certificated for use with natural gas, LPG and bio-propane.

Biopropane can be used if the stove is adjusted for use with LPG (*liquid petroleum gas*), see rating plate under PROPANE.

This manual covers the following models:

Viva 100 L Gas	– without side glass
Viva 100 LG Gas	– with side glass
Viva 100 L Classic Gas	– without side glass
Viva 100 LG Classic Gas	– with side glass
Viva 120 L Gas	– without side glass
Viva 120 LG Gas	– with side glass
Viva 120 L Classic Gas	– without side glass
Viva 120 LG Classic Gas	– with side glass
Viva 160 L Gas	– without side glass
Viva 160 LG Gas	– with side glass
Viva 160 L Classic Gas	– without side glass
Viva 160 LG Classic Gas	– with side glass

The stove is HOT during operation. Wear gloves when operating the stove. Do not operate the stove with an open door, damaged glass, worn or damaged seals. Caution there might be sharp edges.

Revision : 1
Date : 27-03-2019

INTRODUCTION	5
GUARANTEE	6
SPECIFICATIONS	7
DISTANCE/TEMPLATE	7
GENERAL	
GENERAL REMARKS	8
EMERGENCY INTERRUPTION OF GAS SUPPLY	9
INSTALLATION OF STOVE	
INSTALLATION	10
GAS CONNECTION	10
VENTILATION	10
GAS INSTALLATION	10
CHANGING THE CHIMNEY CONNECTION	11
CONVERSION TO BOTTLED GAS (LPG)	14
EARTHQUAKE SAFETY (SEISMIC RESTRAINT)	21
NORMAL INSTALLATION - RECTANGULAR WITHOUT SIDE GLASS	23
NORMAL INSTALLATION - RECTANGULAR WITH SIDE GLASS	24
CORNER INSTALLATION 45° WITHOUT SIDE GLASS	25
CORNER INSTALLATION 45° WITH SIDE GLASS	26
INSTALLATION SPACING FOR NON-FLAMMABLE WALL	27
CHIMNEY/VENT	28
LOCATION OF CHIMNEY TERMINALS	29
HORIZONTAL WALL TERMINAL TYPE C11	30
VERTICAL ROOF TERMINAL C31	31
ASSEMBLY OF SECONDARY BURNER	32
Arrangement of "Embers" and "Logs"	33
START-UP	
BATTERIES	38
SETTING UP THE ELECTRONIC CODE	40
COMMISSIONING	41
INITIAL IGNITION	43
USER INSTRUCTIONS	
REMOTE CONTROL	44
SERVICE	
SERVICE	50
CLEANING	51
ACCESSORIES	52
MYFIRE WI-FI BOX	53
MOUNTING OF 6KG HEAT ACCUMULATION STONES	55
SPARE PART LIST VIVA 100 L GAS - VIVA 120 L GAS - VIVA 160 L GAS	57
SPARE PART LIST VIVA 100 L G GAS - VIVA 120 L G GAS - VIVA 160 L G GAS	58
SPARE PART LIST GAS UNIT	59
TECHNICAL INFORMATION	
TECHNICAL INFORMATION	60
TECHNICAL DATA	62
EXAMPLES OF CHIMNEY SOLUTIONS	64
CHIMNEY COMPONENTS	73
DECLARATION OF PERFORMANCE	77

Introduction

Congratulation on your new RAIS Product.

A RAIS stove is more than just a source of heat, it also expresses how you put the emphasis on good design and high quality in your home.

In order get the most pleasure and benefit from your new stove, it is important that you read the manual thoroughly before it is installed and put to use.

For the purpose of the guarantee and all contact regarding the stove in general, it is important that you can state the stove's production number. We therefore recommend that you write down the number in the form below.

The production number can be found at the bottom of the stove.

Production number: <input type="text"/>
Produced by: RAIS A/S 9900 Frederikshavn, DK

Dealer:

Date:

Installer:

Date:

Guarantee

RAIS stoves are checked several times with regard to safety, as well as the quality of materials and manufacturing. We offer a **2** year guarantee on all models and the guarantee commences on the date of installation. However, wear parts, such as thermal sensors, only one year.

The guarantee covers:

- documented functional faults due to incorrect manufacture
- documented material faults

The guarantee does not cover:

- door and glass gaskets
- ceramic glass
- the appearance of the surface structure or texture of the natural stone
- the appearance of the stainless steel and colour changes and patina
- expansion blemishes
- batteries

The guarantee is invalidated in the event of:

- damage due to overfiring
- damage due to external influences and the use of unsuitable fuels
- failure to comply with statutory or recommended installation instructions and in the event the user's own modifications of the stove.
- lack of servicing and care, the stove must be serviced annually

In the event of damage, please contact your dealer. In the event of claims under the guarantee, we will decide how the damage is to be repaired. In the event of repairs, we will ensure they are performed professionally.

In the event of guarantee claims concerning repaired parts or parts delivered later, please refer to national/provisions in relation to renewed guarantee periods.

The guarantee provisions applying at any time may be requested from RAIS

Specifications

<i>Intertek Ref.: 102929617LHD-001</i>	Viva 100 L Gas	Viva 120 L Gas	Viva 160 L Gas
Nominal heat input (kW): Natural Gas - G20 I2H/I2E	9.1	9.1	9.1
Min. input (kW): Natural Gas - G20 I2H/I2E	1.7	1.7	1.7
Nominal heat input (kW): Propane Gas - G30/G31 I3B/P(30)	8	8	8
Min. input (kW): Propane Gas - G30/G31 I3B/P(30)	1.8	1.8	1.8
Heating area (m ² at -20°):	Approx. 180	Approx. 180	Approx. 180
Stove width/depth/height (mm):	Ø470-1000	Ø470-1200	Ø470-1600
Weight (kg) min., depending on model:	approx. 90	approx. 100	approx. 130
Efficiency (%): (G20 I2H/I2E)	78.3	78.3	78.3
CO content (PPM) (G20 I2H/I2E)	31	31	31
NOx emissions (G20 I2H/I2E)	23	23	23

Maximum Output Natural Gas Net (kW) Gas type G20	6,4
Maximum Output Propane Net (kW) Gas type G31	5,8

Intertek Testing & Certification Ltd,
 Registered office: Academy Place, 1 to 9 Brook Street, Brentwood, Essex
 CM14 5NQ, United Kingdom. Registered No: 3272281
 (England), VAT No: GB 672-7639-96-011
 T: +44 1277 223 400
 F: +44 1277 223 127

See scale drawings at the back of the manual.

General

General Comments

This RAIS product is an extremely effective convection gas stove with a sealed combustion chamber for chimneys with a balanced draught. It is fitted with a burner with the latest burner technology. It has a variable heat output because it uses a special control system that makes it possible to use three burners for high output or one burner for a lower output. One of the burners, called the "Main burner" is located in the centre of the stove, the second and third burners, called the "Secondary burners" are located behind the Main burner. The secondary burners can be switched on and off while the stove is on.

Where there is a natural gas connection, the local gas supply conditions should be investigated to ensure that the gas composition and pressure suit the stove's settings. If the stove is connected to bottled gas, only gas bottles fitted with a gas regulator (Low pressure regulator) providing the correct gas pressure may be connected. For this reason, gas bottles without a regulator must not be connected.

This stove must only be installed, set up and serviced by a Gas safe registered Engineer. The installation must comply with local and national Building Regulations and Gas Regulations and the user manual must be adhered to. The user manual should be left with the customer, who should keep this for later use. The manual is necessary when the stove is to be serviced.

Ensure that the chimney terminal is not blocked in any way and is free of vegetation in the form of trees, bushes etc. and that objects are not resting against the chimney's terminal or the protection around the terminal.

The door glass should always be cleaned before the stove is turned on and fingerprints wiped as these can be burned into the glass.

The stove must not be used if the door glass is split, cracked, removed or if the door is open. Do not use the stove if the door gasket is broken or worn.

This stove is designed for use in many different installation situations, which can be seen in this manual. Only chimneys approved by RAIS may be used with this product. (see chimney section)

This stove is intended for chimneys with balanced draughts (Air intake and draught in same chimney) so there is no need for any extra air supply for combustion.

This product is a heating appliance so the surfaces become very hot and should not be touched during use. It is therefore recommended that you use an approved stove screen to protect children, vulnerable adults, older people and persons with reduced mobility in the same area as the stove.

Keep curtains, washing, furniture etc. at a minimum distance of 300 mm from this stove. The stove must not be used for burning waste.

If the stove is extinguished or goes out, do not attempt to turn it back on until a minimum of 3 minutes have passed.

Emergency interruption of gas supply

Where a smell of gas is detected, the gas supply must be interrupted immediately. Turn off the stove at the isolation tap and the gas meter. Ventilate the room by opening windows and doors, do not use electrical appliances in the vicinity of the stove. Or operate any electrical switches. The gas supply must not be switched on, until a Gas Safe Registered engineer has checked the system and deemed it as being safe.

installation of stove

Installation

It is important that the stove is correctly installed from both an environmental and safety point of view.

The stove must only be installed by a Gas Safe Registered engineer.

When installing the stove, all local rules and regulations, including those referring to national standards must be complied with.

The installation must comply with the Building Regulations and Gas Safety (Installation and use) Regulation.

There must be no unauthorised modifications of the stove.

Before installation begins, it should be confirmed that the information on the data plate regarding gas type and pressure is in accordance with the local gas supply conditions under which the stove is to be installed.

You should ensure that the gas supply can supply the required quantity of gas and pressure as described on the data plate. It is advisable to wear gloves when installing and servicing the stove.

Gas connection

The inlet supply pipe has an external diameter of Ø8mm. An isolation tap must be fitted.

Ventilation

This stove has a sealed combustion chamber and is intended for a balanced draught. There is therefore no need for an extra air supply.

It is recommended that sufficient fresh air is supplied to the room to maintain a comfortable environment.

This stove may be installed in a completely airtight building or a building with mechanical ventilation.

Gas installation

Once it has been decided where the stove will be positioned, a gas installation should be established in the vicinity of the stove so that the gas supply and stove can be connected.

As this stove has a sealed combustion chamber and a built-in plinth, there is no need for a floor slab.

The installation must comply with the Building Regulations, Gas Safety (Installation & Use) Regulations, BS 5871, BS 5440-1, BS 6891 and where relevant all LPG Codes of Practice. LPG stoves must not be fitted in a basement.

PLEASE NOTE!

The floor construction must be able to bear the weight of the stove and chimney, if applicable. If the existing design does not satisfy this prerequisite, suitable measures must be taken (e.g., a load distribution slab). Consult a construction expert.

The stove must be positioned at a safe distance from flammable material.

It must be ensured that flammable objects (e.g., furniture) are not positioned closer than the distances stated in the following sections with regard to installation (risk of fire).

When you choose where you wish to position your stove, you should consider the heat distribution to the other rooms. Then you will get the maximum possible pleasure from your stove.

Inspect the stove for defects upon receipt.

Changes to chimney connection

The stove is supplied ready for a top outlet but can be changed to a rear outlet in the following manner:

Illustrations



1. The knock-out blank at the rear of the stove can be knocked out using a hammer. This may require several blows. Be careful to only hit the blank.

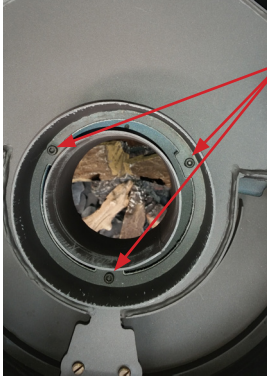

2. Loosen the three screws on the outer flange on the top surface of the stove. And remove it.



4. Unscrew the outer cover plate at the rear of the stove and move it to the upper surface of the stove.



3. Loosen the three screws on the inner flange on the bottom surface of the stove. And remove it.

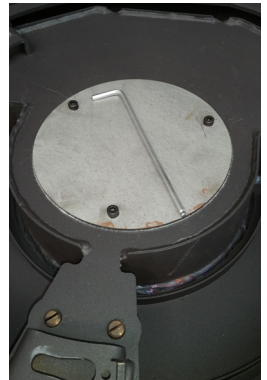

5. To open the door, a 10mm open-ended spanner is required to turn the two catches at the top and bottom of the door.

6. The secondary burners are removed by lifting them vertically up and out.

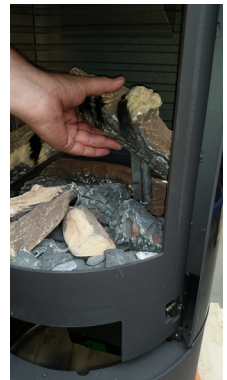



7. If the ceramic logs are fitted remove these.

8. The thin side pieces of the back plate are removed by loosening the two screws, one at the top and one at the bottom. The side pieces can then be removed.

9. The back plate can now be removed and the internal cover plate dismantled.



10. The internal cover plate is now fitted to the underside of the top plate as shown. It is vital that this plate fits and seals correctly

11 Fit the connecting pieces where the cover plates were and replace the back plate, logs and burners.

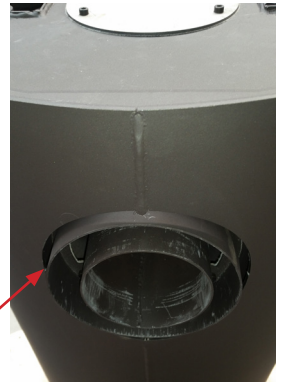

Conversion to bottled gas (LPG)

The stove is supplied configured for natural gas but can be converted to bottled gas (LPG). The conversion must only be carried out by a Gas Safe Registered engineer.

Conversion kit. Use article number 3713595. This set contains 4 new injectors suitable for propane/LPG gas.



The injectors for the secondary burners for LPG are marked "100"

The injectors for the secondary burners for natural gas are marked "260"



LPG

LNG



The injector for the main burner for LPG is marked "80"

The injector for the main burner for natural gas is marked "120"



The injector for the pilot light for LPG is marked "27"

The injector for the pilot light for natural gas is marked "32"

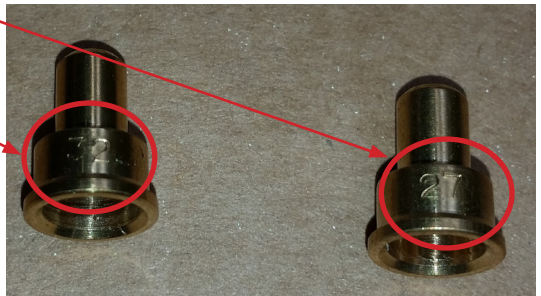

The gas unit needs to be dismantled to gain access to the injectors. Do this in the following manner:

Lift the perforated plate up and out of the stove.



Loosen the four screws holding the gas unit in place.

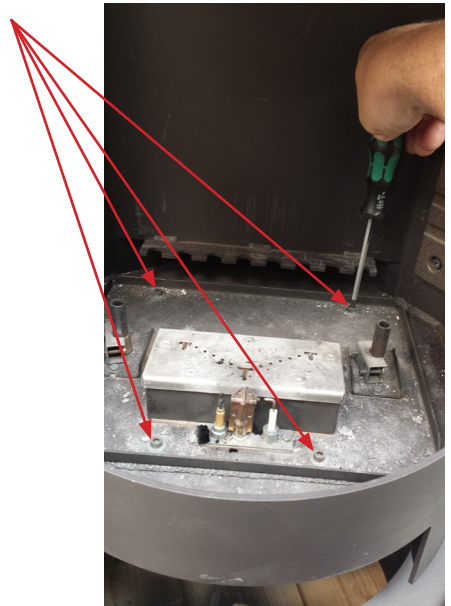

Now the gas unit can be lifted out carefully by tilting and rotating the unit a little.



Once the gas unit has been dismantled, replace the four injectors and adjust the three air intakes.

Replace the two injectors for the secondary burners by loosening the coupling and carefully pulling the pipe out. Loosen the locknut and then unscrew the injector. Fit the LPG injector and tighten the lock nut. Finally, re-tighten the coupling.



Remove the injector for the main burner by loosening the coupling and carefully pulling the pipe out and then unscrewing the injector. Fit the LPG injector and tighten the lock nut. Finally, re-tighten the coupling.

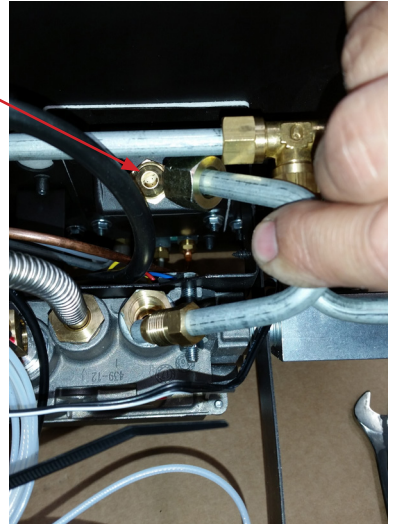

Replace the injector for the pilot light by loosening the coupling and carefully pulling the pipe out. Note. The small pilot light injector should now fall out and can be replaced with the LPG injector.



The air intake to the main burner is adjusted for LPG configuration by loosening the two nuts and pushing the plate all the way towards the burner. (The hole fully open)

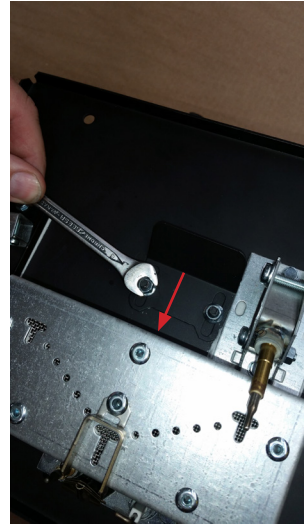

The two air intakes for the secondary burner are adjusted for LPG configuration by loosening the two screws and rotating the air intake by 90°. So that both holes in the vertical pipe are now open. (the small one at the rear and the large one at the front)

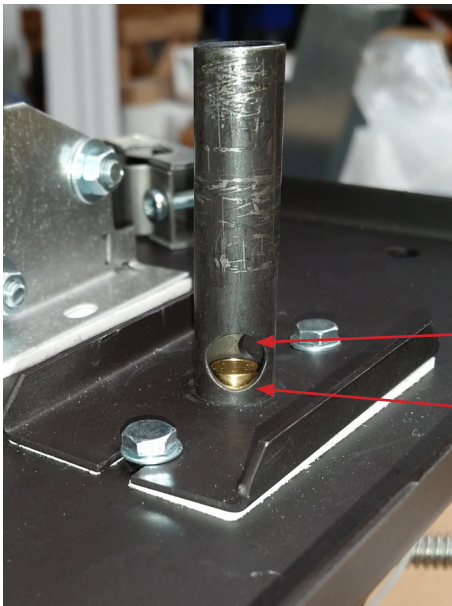
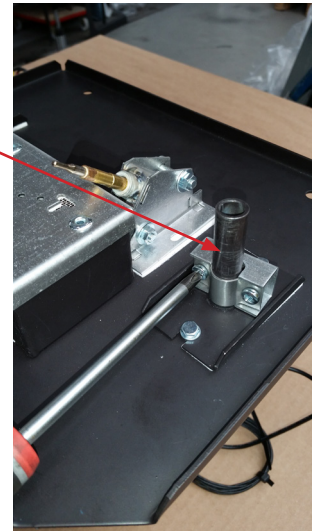

Small hole at the rear

Large hole at the front

The air intakes need to be reversed therefore when the stove is configured for LPG.

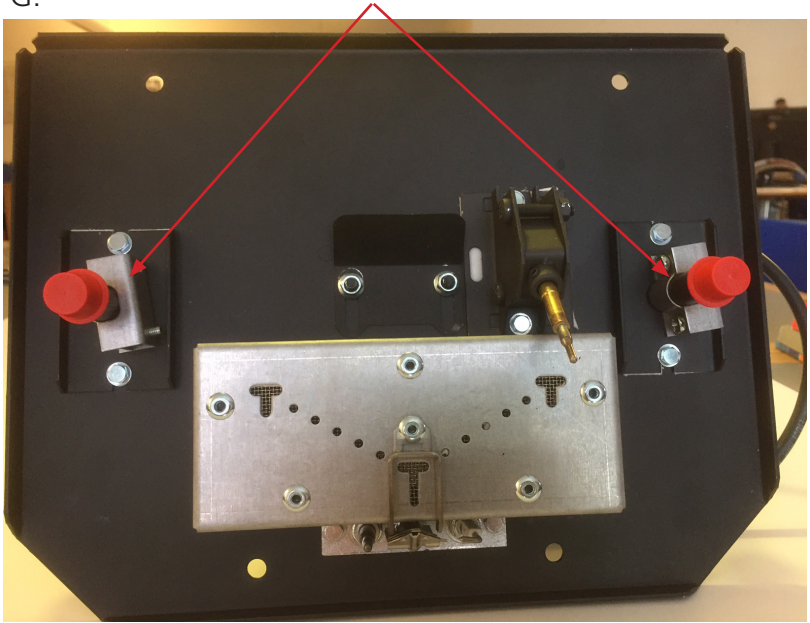

The gas unit is reassembled using the four screws. Replace the perforated plate and fully assemble the stove.
See Section: Assembly of secondary burners.



Earthquake safety (seismic restraint)

The stove has to be fixed to the floor in the event of an earthquake. Therefore the stove is supplied with a floor fixing plate.

Loosen the four bolts and push the brackets towards the center of the fixing plate. Fix the bottom plate to the floor using the eight slits.

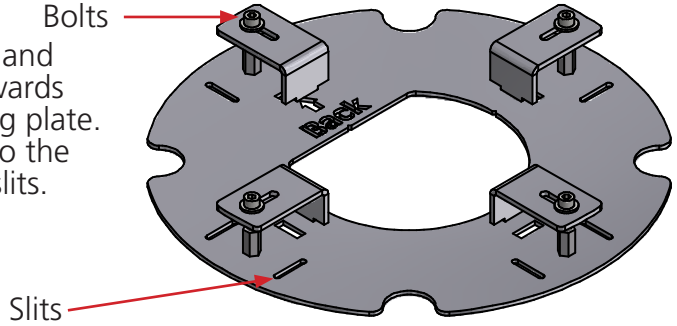

Place the stove over the fixing plate.

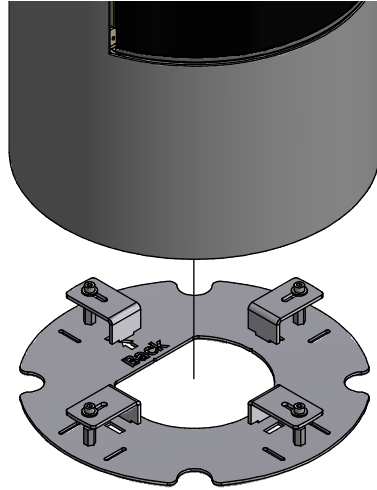

Remove the air inlet cover on the back of the stove, to gain access to the fixing plate.

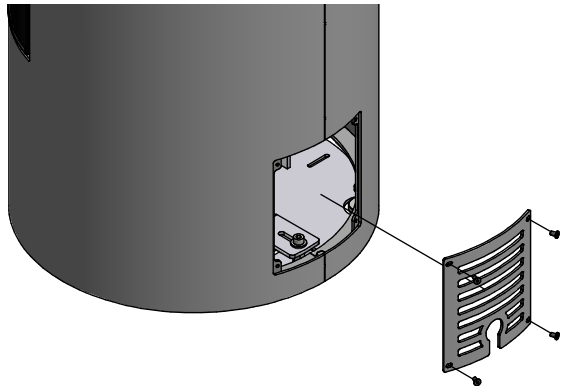

Through the air inlet at the back,
Push the brackets outwards until they
fall into place in the designated holes
in the bottom plate.
Tighten the four screws again fixing
the stove to the floor.

Note.
The adjustable feet might have to be
adjusted!

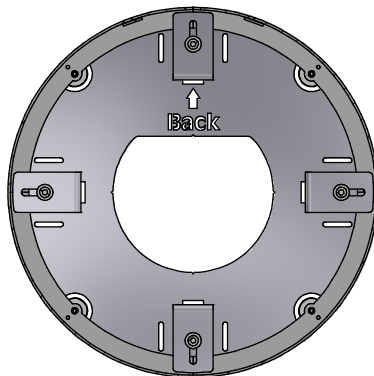

Installation distance from flammable wall

In order to clarify whether the wall your stove will stand alongside is flammable, you can contact your building architect or the local building authorities.

It must be ensured that flammable objects (e.g., furniture) are not positioned closer than the distances stated in the following tables (risk of fire).

Normal installation - at right angle Without side glass	Viva 100 L Gas Viva 120 L Gas Viva 160 L Gas
A. Furniture distance (min.)	700 mm

Distance to flammable material (min.)

D. rear (wall)	50 mm
E. to side to wall	250 mm

Norwegian Firewall

D. rear (wall)	50 mm
E. to side to wall	225 mm
O. Extent of firewall to the side	75 mm
P. Extent of firewall to front	500 mm

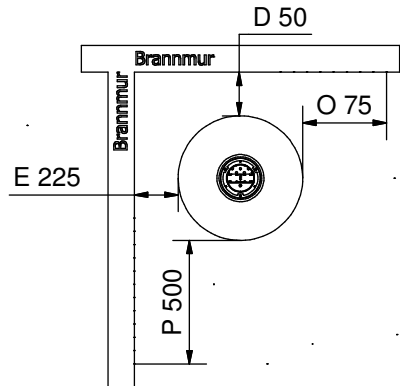
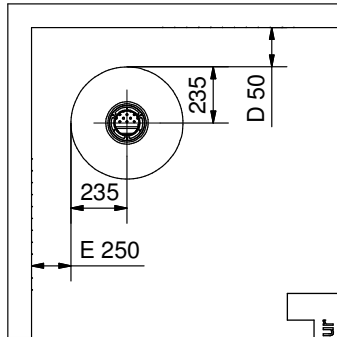
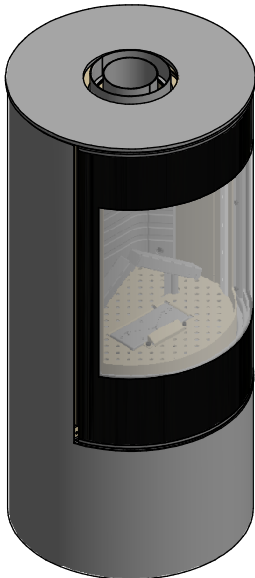

**Normal installation - at right angle
With side glass**

**Viva 100 L G Gas
Viva 120 L G Gas
Viva 160 L G Gas**

A. Furniture distance (min.)	700 mm
Distance to flammable material (min.)	
D. rear (wall)	50 mm
E. to side to wall	300 mm

Norwegian Firewall

D. rear (wall)	50 mm
E. to side to wall	300 mm
O. Extent of firewall to the side	425 mm
P. Extent of firewall to front	400 mm

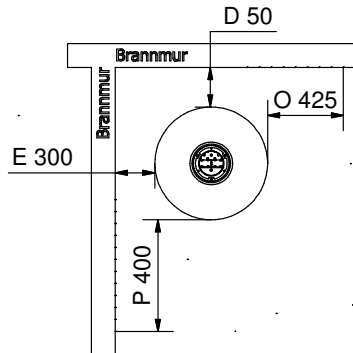
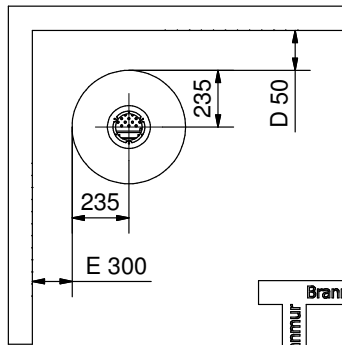
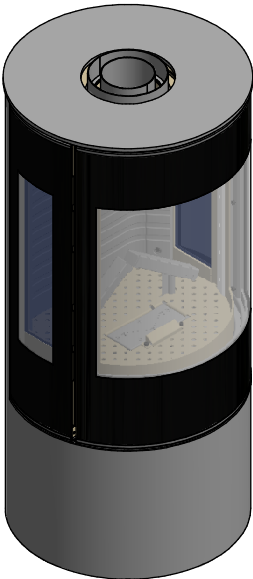

**Corner installation 45°
Without side glass**

**Viva 100 L Gas
Viva 120 L Gas
Viva 160 L Gas**

A. Furniture distance (min.)	700 mm
Distance to flammable material (min.)	
D. rear (wall)	50 mm

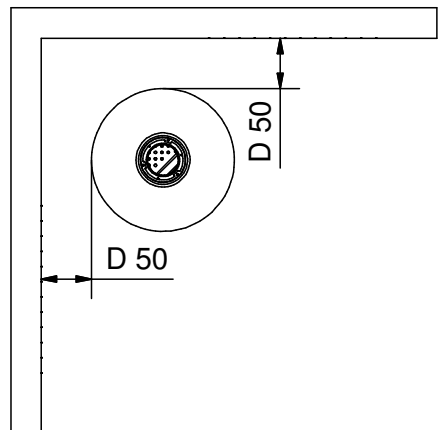
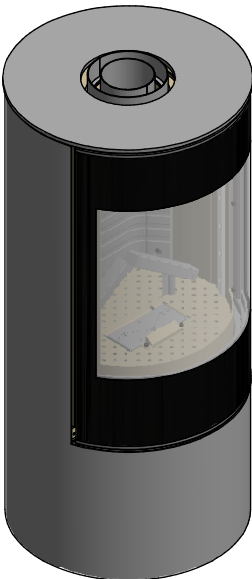

**Corner installation 45°
With side glass**

**Viva 100 L G Gas
Viva 120 L G Gas
Viva 160 L G Gas**

A. Furniture distance (min.)	700 mm
Distance to flammable material (min.)	
D. rear (wall)	150 mm

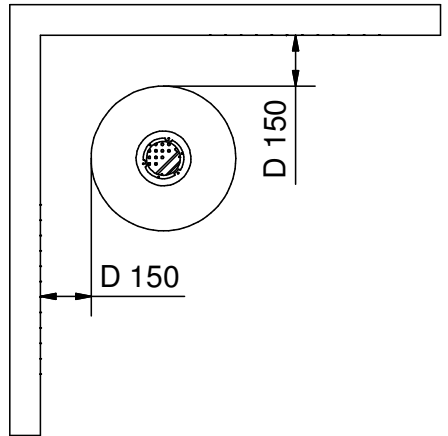
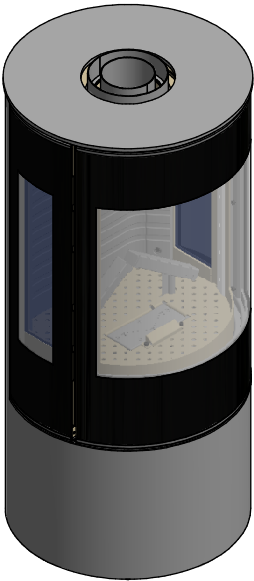

Installation distance at non-flammable wall

We recommend a minimum distance of 75mm (F) to non-flammable material to allow service and installation. Where the outlet is to the rear, there should however be space for a measuring connection piece for combustion control.

Normal installation - at right angle

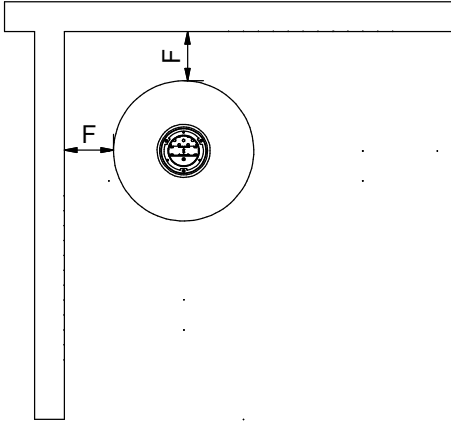

Corner installation 45°

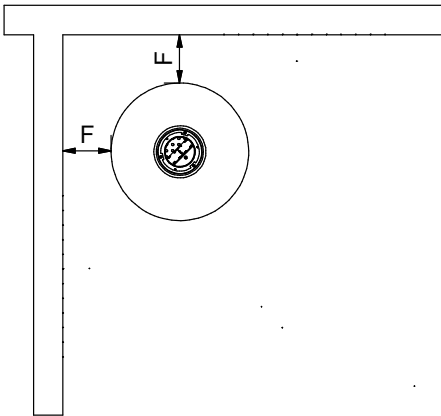

Chimney/Flue

This stove must be either installed with a vertical terminal (C31) or a horizontal terminal (C11)

Must only be installed with a flue with a balanced draught (also known as a concentric draft) as stated by RAIS.

The flues approved by RAIS are approved for use with the stove. If the stove is installed with flues other than those approved by RAIS, RAIS cannot guarantee or accept responsibility for the correct and safe functioning of the stove. and will invalidate the CE mark.

RAIS recommends that the stove be installed with a chimney of the following make:

On-Top-Metalotherm USD or **On-Top-Metalotherm US**.

Other approved chimney products are: **Jeremias, Muelink & Grol, Poujoulat PGI**.

Joints at vent pipes must be airtight and protected against separation by using locking bands, or suitable rivets / screws.

If possible a measuring connection piece should be installed on the flue in the same room as the stove so that a combustion check can be performed. Where the terminal is accessible, this is unnecessary.

Ensure the flue terminal position complies with Building Regulations Approved Document J, BS EN 5440-1 and the label in these instructions

Ensure that flue products cannot re-enter the property even if compliant with the regulations. If the terminal is below 2m above ground level, a terminal guard must be fitted. Flue assembly must follow the flue manufacturer's instructions.

The chimney is the driver for getting the stove to work. The stove will not work optimally unless there is the necessary and correct draught in the chimney.

The stove is supplied with smoke connecting pieces prepared for internal assembly of the outflow pipe.
with diameter Ø100/Ø150

Piping

When you start piping to the gas fireplace, it is important that the flue pipe is facing correctly. The end with only a single "ring" must turn into the gas fireplace. See picture.



Location of chimney terminals

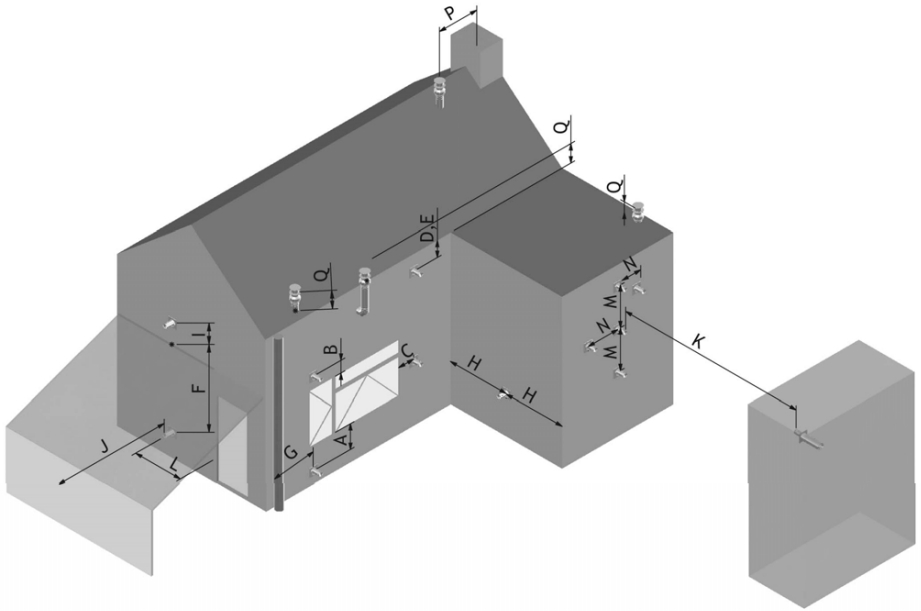

Dimension	Terminal Position	Distance (mm)
A*	Directly under an opening, an open window or ventilation duct	600
B	Above an opening, an open window or ventilation duct	300
C	Alongside an opening, opening window etc.	400
D	Under gutter, earth pipes or drainpipes	300
E	Under eaves	300
F	Under balconies or carport roof	600
G	From a vertical drainpipe or earth pipe	300
H	From an internal or external corner	600
I	Overground roof or balcony level	300
J	From a surface facing the terminal	600
K	From a terminal facing the terminal	600
L	From an opening in carport (e.g., door, window into the dwelling)	1200
M	Vertical from a terminal on same wall	1500
N	Vertical from a terminal on same wall	300
P	From a vertical construction on the roof	600
Q	Above the intersection with roof	300

29 * In addition, the terminal must not be closer than 300 mm to an opening in the building, such as a window or a door.

Horizontal Wall Terminal type C11

Dimension of outflow pipe:

Viva L Ø100 / Ø150 Outlet connection piece on the stove
 Ø100 / Ø150 Can be used for the entire chimney, or,
 Ø130 / Ø200 Adapter can be used so that you can use
 Ø130 / Ø200 after the adapter.

Outlet terminal Ø130 / Ø200 Art. no. USDHC 130
 Ø100 / Ø150 Art. no. USDHC 100

Maximum length of outflow pipe to external wall (H)

= 4 X Vertical outlet pipe length (V) -1. for Ø130 / Ø200 pipe.

= 2 X Vertical outlet pipe length (V) . for Ø100/Ø150 pipe.

Maximum permissible length (H) = 15M.

Minimum vertical height of outlet pipe for Viva L = 0.5m

vertical length of out- let pipe (V) in metres	Maximum length of Horizontal outlet pipe (H) in metres Ø130/ Ø200	Maximum length of Horizontal outlet pipe (H) in metres Ø100/ Ø150
0.5	1	1
1	3	2
1.5	5	3
2	7	4
2.5	9	5
3	11	6
3.5	13	7
4	15	8
4.5	15	9
5	15	10
5.5	15	11
6.5	15	13
7	15	14
7.5 <	15	15

Flue restrictor to Ø100/Ø150

Vertical height < 1m
 Vertical height 1-2m
 Vertical height > 2m

No flue restrictor
 Ø62mm flue restrictor
 Ø76mm flue restrictor

Vertical roof terminal type C31

Dimension of outflow pipe:

Viva L $\varnothing 100 / \varnothing 150$ Outlet connection piece on the stove
 $\varnothing 100 / \varnothing 150$ Can be used for the entire chimney, or,
 $\varnothing 130 / \varnothing 200$ Adapter can be used so that you can use
 $\varnothing 130 / \varnothing 200$ after the adapter.

Outlet terminal $\varnothing 130 / \varnothing 200$ Art. no. USDVC 130
 $\varnothing 100 / \varnothing 150$ Art. no. USDVC 100

Minimum vertical length of outlet pipe 0.5m

Flue gas limiter

You need to mount one of the flue gas limiters, if the chimney is more than one meter in vertical height. Mount it inside the burning chamber in the flue outlet.

Flue gas Limiter for $\varnothing 100/\varnothing 150 - \varnothing 130/\varnothing 200$ mm chimney

Vertical height < 1m No limiter
Vertical height 1-2m $\varnothing 62$ mm limiter
Vertical height > 2m $\varnothing 76$ mm limiter

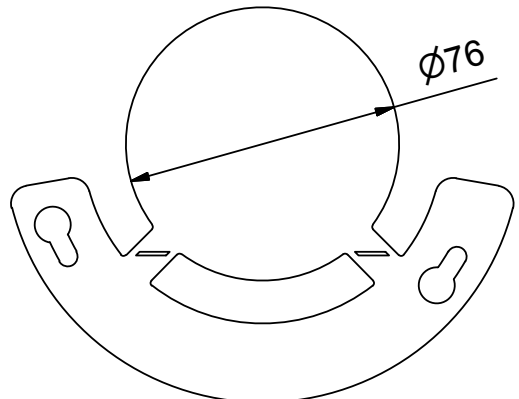
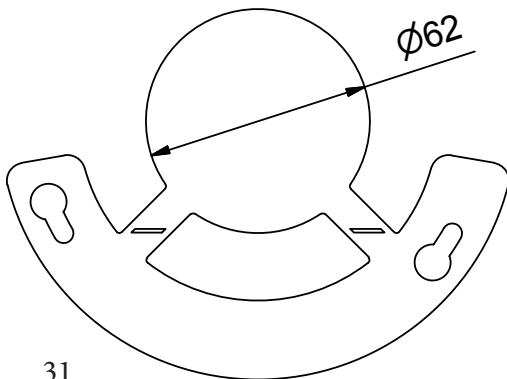

Fitting of Secondary burners

The burners are inserted above the pipes sticking through the perforated plate. Note that there is a right burner and a left one so it is important that they are positioned as shown, i.e., that the side with the extra holes faces the front.

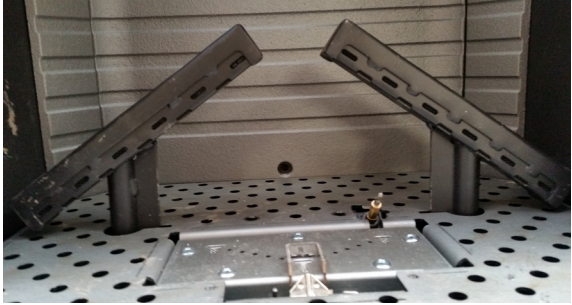

Front with holes



Rear without holes



Arrangement of "Embers" and "Logs"

When layers of embers and the ceramic logs are arranged in the combustion chamber, it is important that the pilot flame and its thermosensor are not covered over. And that no glowing material finds its way down under the pilot plate guard. The other thermosensor must also be kept free of the ceramic "Embers".

2nd thermosensor

Pilotflame

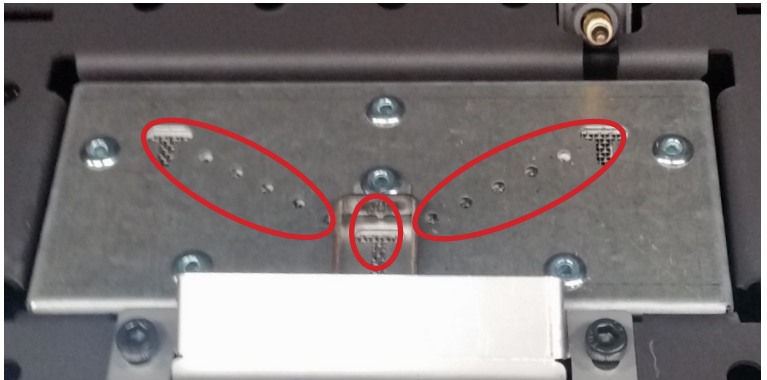
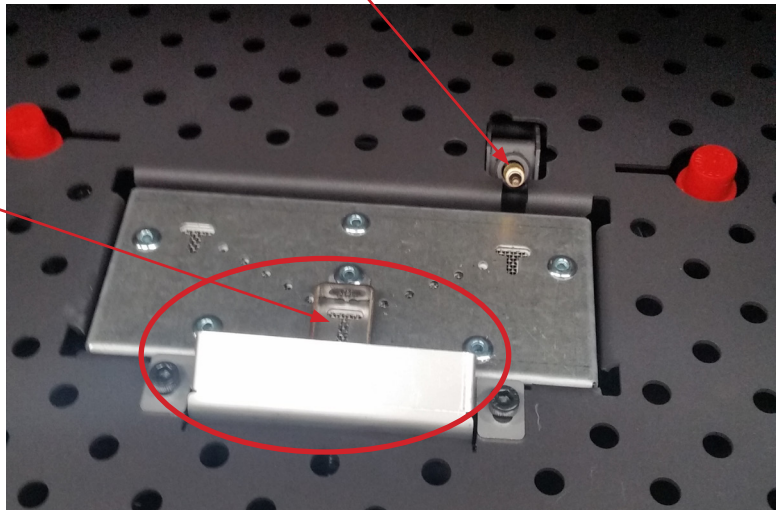

When commissioning or servicing the stove, it should be ensured that the cross-ignition from the pilot to the main burner works and that the secondary burners are easily ignited.

ceramic "Logs

Log A



Log B



Log 1



Log 2



Log 3



Log 4



Log 5



Log 6



Positioning of Logs and Embers

Spread the content of the bag of "Embers" as shown in the illustration. Note: The pilot area must be kept clear of "Embers". Be sure not to block the holes of the center burner. Position the 8 logs as shown. Note, the two special logs marked A and B have a groove moulded on their undersides that fits on top of the two secondary burners. The glow wires are positioned between the "Embers" on the center burner to emphasise the glow effect.



Log 1



Log 2

Log 2 must not touch the 2nd thermosensor

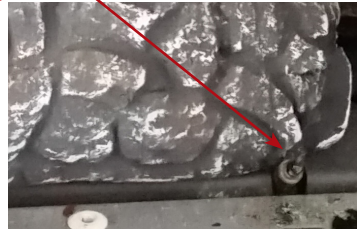



Log 3



Log 4



Log 5



Log 6

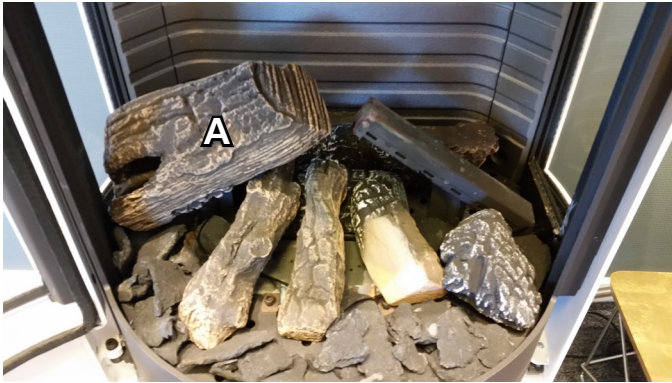

Log A

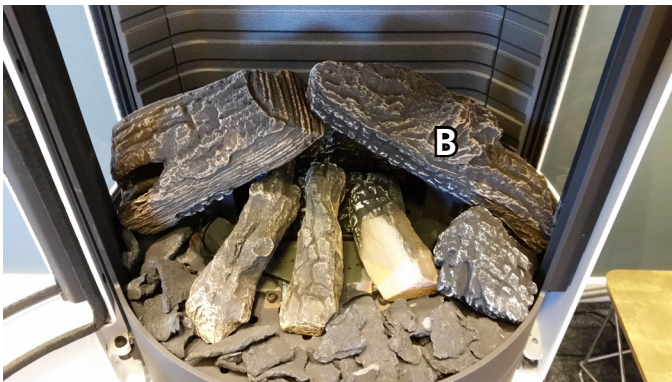

Log B

Start-up

Insertion of Batteries.

The receiver on the stove and the remote control use batteries.

A set of batteries to be inserted prior to start-up is included. To access the battery box on the receiver, open the door by rotating the two catches at the right-hand side by means of the 10mm open-ended spanner provided.

The receiver is located under the combustion chamber.

Push the battery cover on the receiver to the left to open it.

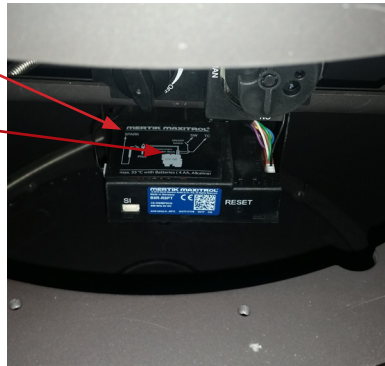

Use only good quality Alkaline batteries.

The batteries should be replaced at the start of a new heating season.

All batteries should be changed at the same time.

The batteries are removed from the receiver by pulling the red tab.

Never use sharp tools to tip the batteries out of the box.

The receiver uses 4 x AA 1.5 V batteries. Remember to replace the battery cover.

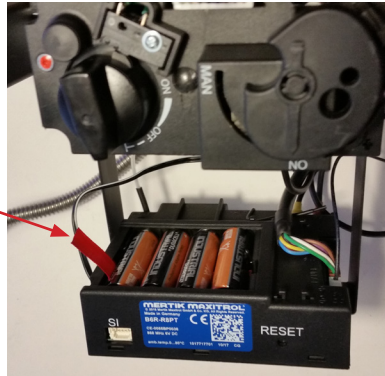

The batteries in the receiver must face the directions shown in the illustration.



The remote control uses 2 x AA 1.5 V batteries.



SETTING UP OF THE ELECTRONIC CODE

In order for the remote control to work, it must be synchronised with the stove's receiver. A code is selected automatically and at random from 65,000 possible codes. The stove and remote control are synchronised in the following manner.

Press and hold down the "Reset" button until you hear a short beep followed by a long beep. Release the button.



Now you have 20 seconds to press the "Down Arrow" button on the remote control. Hold down the button until you hear two short beeps from the receiver. Now you can see the word "conn" on the remote control.

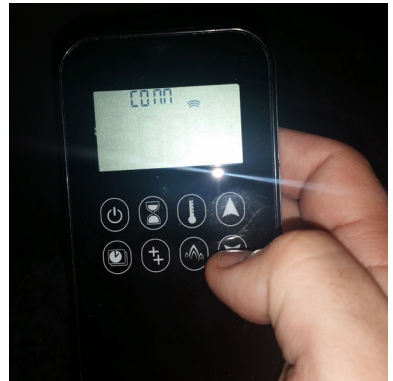

The receiver and remote control are now synchronised.

Commissioning

Check functioning of pilot light.

See User Instructions for use of remote control.

1. Start the pilot light.
2. Check that the pilot light remains ignited.
3. Turn off the pilot light.

Check the functioning of the main burner.

1. Turn on the pilot light
2. Turn on the main burner.
3. Check that the cross-ignition from the pilot light to the main burner occurs easily and that the main burner and pilot light remain ignited.
4. Check that the secondary burner's functions work.
5. Turn the stove off entirely.

Pressure Test

The stove is preset to provide the correct amount of heat (kW) as described under specifications. There is usually no need for further adjustment. "Inlet pressure" and "Burner pressure" must **ALWAYS** be measured. And corrected if necessary.

1. Close the gas valve (Main Valve Knob)
2. Open the "Inlet pressure tap" on the gas valve and connect a manometer.
3. Check that the pressure measured concurs with the prescribed pressure from the gas supply company.
4. Carry out the test when the stove is at maximum heat output, including the secondary burners and when the stove only has the pilot light ignited.
5. If the pressure is low, check that the gas supply pipes are the correct size.
6. If the inlet pressure is too high (more than 5 mbar over), the gas supply must be corrected before the stove is commissioned.
7. The screw for the "Outlet pressure tap" on the gas valve is loosened and a manometer connected
8. Check that the pressure measured concurs with the pressure stated on the rating plate.
9. The value measured must be within $\pm 10\%$ of the stated pressure. correct as necessary (see gas valve diagram)

Note. After the pressure test and removal of the manometer, the screws in the "pressure tap" should be retightened. Check the system for gas leaks.

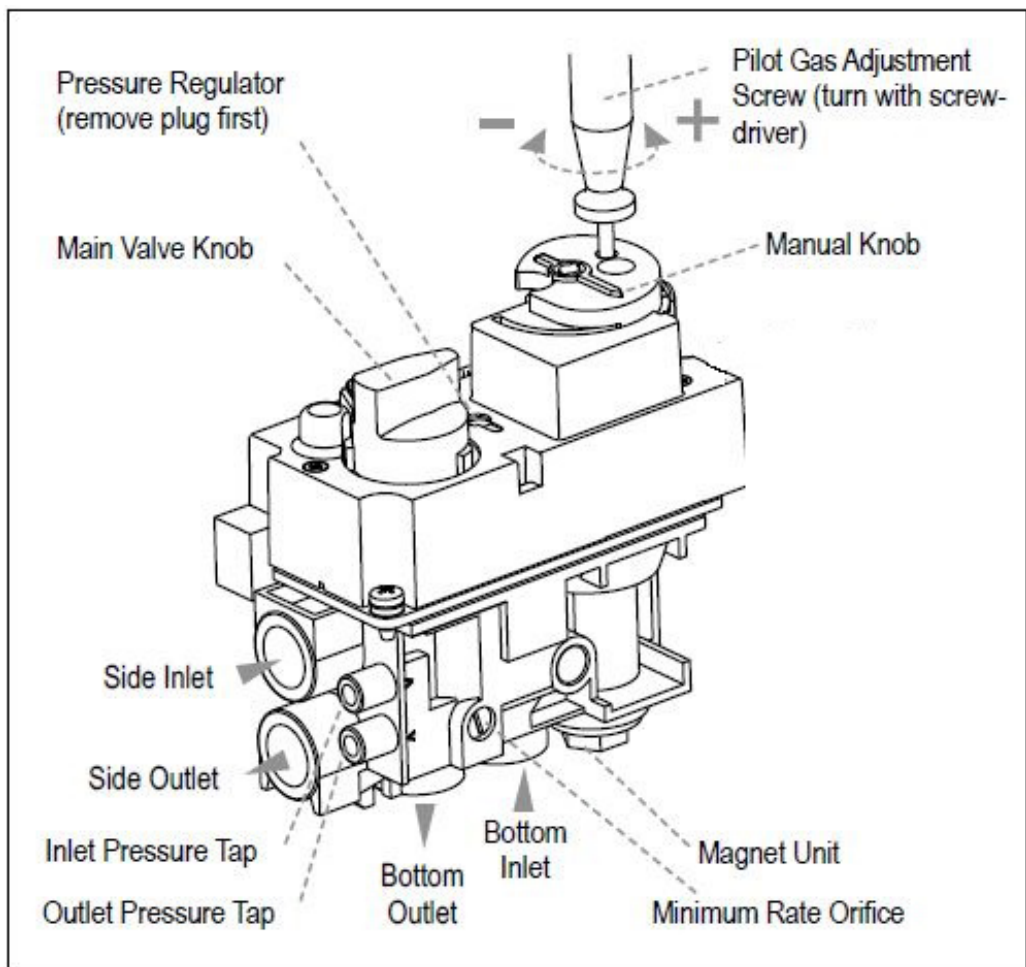

Initial ignition

Before the initial ignition, ensure that all packaging, labels etc. have been removed from the stove and that the door glass has been cleaned.

Begin at low output, then the stove can be slowly turned up to a greater output. When the stove has been heated up, allow the stove to burn at high output for a couple of hours. This allows the best start and any damage is avoided.

Be aware that a strange smell and smoke from the stove's surface may occur during the initial ignition. This is because the paintwork and material need to harden but the smell will quickly disappear.

Ensure there is a lot of ventilation, preferably a draught. Children and pets should be kept at a safe distance from the stove during this process.

During this process, you should be careful not to touch the visible surfaces/glass (very hot!).

In addition, while heating up and cooling down, the stove may emit a so-called "clicking sound". This is due to the great differences in temperature the material is exposed to.

When the stove has been unused for a while, use the same approach as during the initial ignition.

Do not operate the stove with the door open!

User instructions

USER INSTRUCTIONS

GENERAL NOTES

NB!

The wiring for valves and receiver must be closed off before the ignition is put on. Failing to do so could damage the electronic system.

Batteries – Handset

- Low battery indicator on the handset.

Batteries – Receiver

- Low battery indicator: frequent beeping for 3 minutes when the motor is running.
- An AC adapter connected to a socket can be used instead of batteries.



WARNING

- If the mains adapter and battery are not used, it is recommended that they are replaced at the start of each heating season.
- Old or dead batteries must be quickly removed. If the batteries are left in the unit, they may overheat, leak and/or explode.
- Do NOT expose the batteries (even during storage) to direct sunlight, strong heat, fire, moisture or strong impacts. All these factors could contribute to the battery overheating, leaking and/or exploding.
- The batteries must be stored within the recommended temperature range. (Range of the battery's ambient temperature: 32-131 °F (0-55 °C)).
- New and old batteries should not be used at the same time. The same applies to batteries of different makes. If different batteries are used at the same time, this could contribute to the battery overheating, leaking and/or exploding.

Software version

Press on the  and  buttons at the same time. Now the software version is displayed.

Model number of the handset

Press on the  and  buttons at the same time. Now the model number of the handset is displayed.

Deactivation of functions

1. Install batteries All icons are displayed and flash.
2. While the icons are flashing, press on the relevant function button and hold down for 10 seconds.
3. The function icon remains flashing until deactivation is completed. Deactivation has been completed when the function icon and two horizontal lines are displayed.

NOTE: When you press on a deactivated button, nothing happens and two horizontal lines are displayed.

NOTE: Deactivation remains in effect after replacement of batteries.

Activation of functions

1. Install batteries All icons are displayed and flash.
2. A function is activated by pressing the relevant button and holding it down for 10 seconds.
3. The function icon continues to flash until activation is completed. Activation is completed when the function icon is displayed.

The following functions can be deactivated/activated

- CHILD PROOFING
- PROGRAM MODE
- THERMOSTATIC MODE (also deactivates PROGRAM MODE)
- ECO MODE
- LIGHT/DAMPER (OPERATION)
- ROOM VENTILATOR (OPERATION)
- HELP FUNCTION
- COUNTDOWN TIMER

Do not use the stove with the door open or if the glass is broken or cracked. Do not use if the door seal is broken or worn.

If the stove is extinguished or goes out, do not attempt to relight it until a minimum of 3 minutes has elapsed.

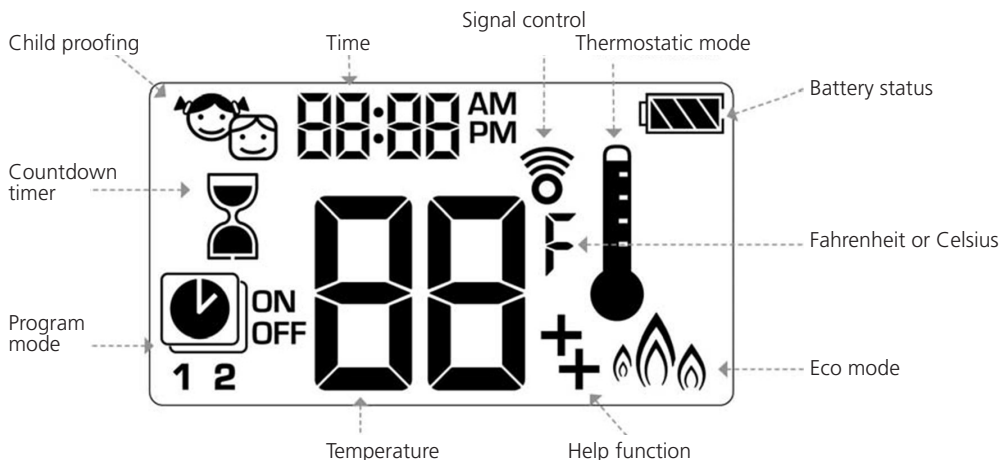

SETTING OF FAHRENHEIT or CELSIUS



Change between °C and °F by pressing and holding the and buttons at the same time.

NOTE: When °F is selected a twelve hour clock is displayed. When °C is selected a twenty-four hour clock is displayed.

CHILD PROOFING

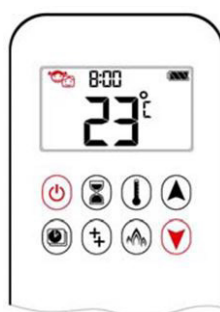

ON: Activation takes place by pressing the and buttons at the same time. When is displayed, the handset cannot be used, apart from the OFF function.

OFF: De-activation takes place by pressing the and buttons at the same time. disappears.

SETTING THE TIME

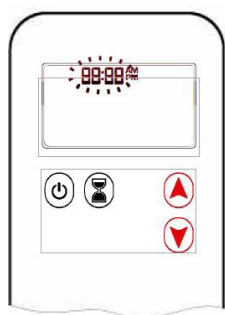

1. Press on the and buttons at the same time. **Day** flashes.
2. Press on the or button in order to select a number corresponding to day of the week (e.g., 1=Monday, 2=Tuesday, 3=Wednesday, 4=Thursday, 5=Friday, 6=Saturday, 7=Sunday).
3. Press on the and buttons at the same time. **Hour** flashes.
4. Select hour by pressing on the or button.
5. Press on the and buttons at the same time. **Minutes** flashes.
6. Select minutes by pressing on the or button.
7. This is confirmed by pressing the and buttons at the same time or waiting.

HOW TO IGNITE

⚠️WARNING

When pilot ignition is confirmed, the motor automatically goes to maximum flame height.

One-button operation of handset

(Default setting)



- Press **⏻** the button until you hear a short beep and a series of flashing lines confirm that the start sequence has commenced. Then release the button.
- The main gas supply starts as soon as pilot ignition is confirmed.
- The handset automatically goes into Manual mode after ignition of the main burner.

NB!

Move from one-button to two-button ignition by pressing and holding down the **⏻** button for 10 seconds immediately after inserting the batteries. **ON** is displayed, and **1** flashes. When the change is made **1** changes to **2**.



Two-button operation of handset

- Press the **⏻** and **▲** buttons at the same time until you hear a short beep and a series of flashing lines confirm that the start sequence has commenced. Then release the buttons.
- The main gas supply starts as soon as pilot ignition is confirmed.
- The handset automatically goes into Manual mode after ignition of the main burner.

NB!

Move from two-button to one-button ignition by pressing and holding down the **⏻** button for 10 seconds immediately after inserting the batteries. **ON** is displayed, and **2** flashes. When the change is made **2** changes to **1**.

⚠️WARNING

If the pilot light does not ignite after several attempts, turn the main valve button to **OFF**. Then follow the guidance for "SHUTTING OFF GAS TO APPLIANCE"

IN STANDBY MODE (PILOT LIGHT)

HANDSET

- Press and hold down the **⏻** button to set the appliance to pilot light.

HOW TO EXTINGUISH THE FIRE

HANDSET

- Press the **⏻** button to **EXTINGUISH**

NOTE: There will be a delay of 5 seconds before it is possible to re-ignite.

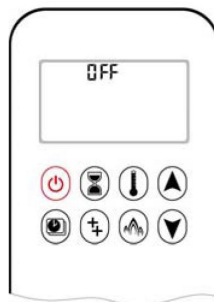

ADJUSTMENT OF FLAME HEIGHT

Handset

- The flame height is increased by pressing and holding down the **▲** button.
- To reduce the flame height or set the appliance to pilot flame, press and hold down the **▼** button.



SELECTING LOW FLAME and HIGH FLAME

NOTE: The background light must be on in order to obtain double-click operation with high and low flame.

- Low flame is activated by double-clicking on the **▼** button **LO** is displayed.

NOTE: The flame goes to high first before going to low flame.

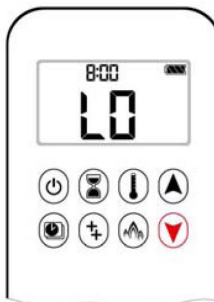



•High flame is activated by double-clicking on the button **HI** is displayed.



Program mode
PROGRAMS 1 and 2 can both be programmed to start or stop at specific times at a set temperature.

⚠WARNING

If the appliance does not work, follow the guidance "SHUTTING OFF GAS TO THE APPLIANCE"



Eco mode
The flame height fluctuates between high and low. If the room temperature is lower than the temperature set, the flame height remains at high for a longer period of time. If the room temperature is higher than the temperature set, the flame height remains at low for a longer period of time. A cycle lasts 20 minutes.

COUNTDOWN TIMER



SETTING OPERATING TIME

1. Press and hold down the button until is displayed and **HOUR** flashes.
2. Select hour by pressing on the or button.
3. This is confirmed by pressing on the button. **Minutes** flashes.
4. Select minutes by pressing on the or button.
- 5 This is confirmed by pressing on the button.

OFF:
Press the button. Now and the countdown time disappear.

NB! Once the countdown has passed, the fire is extinguished. The countdown timer only works in Manual, Thermostatic and Eco modes. The maximum countdown time is 9 hours and 50 minutes.

OPERATING MODES



Thermostatic mode
The room temperature is measured and compared to the temperature set. The flame height is then adjusted automatically to reach the temperature set.

THERMOSTATIC MODE



ON:
Press the button. is displayed, the pre-set is briefly displayed and then room temperature is displayed.

- OFF:**
1. Press the button.
 2. Hold the or button down to enter Manual mode.
 3. Press the button to enter Program mode.
 4. Press the or button to enter Eco mode.



SET-UP:

1. Press the button and hold it down until is displayed and the temperature flashes.
2. The set temperature is adjusted by pressing on the or button.
3. Confirm this by pressing the button or waiting.

PROGRAM MODE



ON:
Press the button 1 or 2, ON or OFF is displayed.

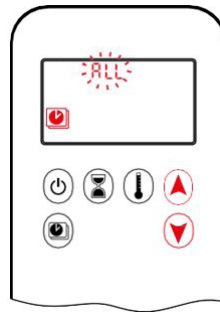

SETTING THE DAY:
5. **ALL** flashes. Press the or button to select from **ALL, SA:SU, 1, 2, 3, 4, 5, 6, 7**.
6. This is confirmed by pressing on the button.

ALL is selected.



OFF:
1. Press on the or or button to enter Manual mode.
2. Press on the button to enter Thermostatic mode.

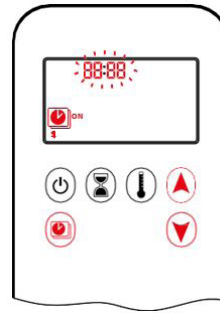

SETTING OPERATING TIME (PROGRAM 1):

7. 1, **ON** is displayed, **ALL** is displayed briefly and **HOUR** flashes.
8. Select hour by pressing on the or button.
9. This is confirmed by pressing on the button.
 1, **ON** is displayed, **ALL** is displayed briefly and **Minutes** flashes.
10. Select minutes by pressing on the or button.
11. This is confirmed by pressing on the button.

SETTING TIME FOR TURNING OFF (PROGRAM 1):

12. 1, **OFF** is displayed, **ALL** is displayed briefly and **HOUR** flashes.
13. Select hour by pressing on the or button.
14. This is confirmed by pressing on the button.
 1, **OFF** is displayed, **ALL** is displayed briefly and **Minutes** flashes.
15. Select minutes by pressing on the or button.
16. This is confirmed by pressing on the button.

NB! The temperature set for Thermostatic mode is the temperature for the operating time in Program mode. If the time set for Thermostatic mode is changed, the temperature for the operating time in Program mode also changes.

Default setting:

OPERATING TIME (thermostatic mode) TEMPERATURE: 21 °C (70 °F)
TEMPERATURE FOR TURNING OFF "--" (only pilot light)



SETTING THE TEMPERATURE:

1. Press the button and hold it down until flashes. **ON** and the temperature set (setting in Thermostatic mode) are displayed.
2. Continue by pressing the button or waiting. **OFF** is displayed and temperature flashes.
3. Select temperature at which to shut down by pressing on the or button.
4. This is confirmed by pressing on the button.

NB! The temperature set (Thermostatic mode) and temperature for shutting down are the same for each day.



NB! Either continue to PROGRAM 2 and set operating time and time for shutting down or stop programming here. PROGRAM 2 remains deactivated.

NB! PROGRAMS 1 and 2 use the same operating temperature (Thermostatic mode) and temperature for shutting down for ALL, SA:SU and Daily Timer (1, 2, 3, 4, 5, 6, 7) When a new operating temperature (Thermostatic mode) and temperature for shutting down have been set, this temperature will become the new default setting.

NB! If ALL, SA:SU or Daily Timer are programmed for operating temperature and temperature for shutting down for PROGRAM 1 and PROGRAM 2, these will become the new default times. The batteries must be removed to clear temperatures, operating times and times for shutting down for PROGRAM 1 and PROGRAM 2.

SA:SU or Daily Timer (1, 2, 3, 4, 5, 6, 7) is selected.



- Set operating time and time for shut down by using the same approach as during "ALL selected" (above).
- SA:SU Set operating time and time for shut down for both Saturday and Sunday.
- Daily Timer: Unique operating times and times for shut down can be set for an individual weekday, for several week days or for all days of the week.
- Wait until set-up is complete.

HELP MODE



After ignition, burner 1 is ignited and burner 2 is in the last setting.



ON:

A burner is ignited by pressing the  button.  is displayed.

OFF:

A burner is turned off by pressing the  button.  disappears.

NB! The locking magnet valve cannot function manually. If the battery in the receiver runs out of power, it will remain in the last operating setting.



ECO MODE



ON:

Press the  button to enter Eco mode.  is displayed.

OFF:

Press the  button.  disappears.

Service.

The stove should be inspected by a Gas Safe Registered engineer once a year. As a minimum, this inspection should ensure that the stove is working correctly and is safe to use.

Service.

Turn off the stove and shut off the gas supply. Ensure the stove is completely cold before starting. Rais cannot be held responsible for injuries arising from touching a hot stove.

Proposed service procedure.

1. Protect the floor by laying down a mat or other covering.
2. Open the door and carefully remove the ceramic logs including embers.
3. Use a vacuum cleaner to clean the burner and perforated sheet.
4. Lift and remove the secondary burners. Lift out the perforated sheet.
5. Vacuum the entire burner.
6. Clean the pilot burner with a soft brush and a vacuum cleaner. The thermosensors must not be bent or adjusted.
7. Put on the gas supply and check for leaks. Check that the burners and pilot unit are in good condition and work.
8. Refit the perforated plate
9. Refit embers and ceramic logs.
10. Check the flue gas system and chimney terminal and ensure it is not blocked.
11. Turn on the stove and check the set pressure.
12. Ensure the stove is safe to use.
13. Check that the door and other seals are in good condition and effective.
14. Worn components should be replaced with new.
15. Old fuel bed components can be placed in a strong plastic bag, sealed and disposed along with household rubbish.

Cleaning

It is advisable to clean the stove of dust and foreign bodies each new heating season and especially if the stove has not been used for a long time. This can be done with a soft brush and a vacuum cleaner. Or with a damp cloth with a non-abrasive cleaning agent. Do not use corrosive or abrasive substances to clean this stove. The stove should be cold when cleaning and taking care of it.

If the glass is sooty:

- Only clean the glass when the stove is cold.
- Cleaning should be done with glass cleaner, which can be purchased from your RAIS dealer.

External cleaning is done using a soft dry cloth or brush only.

Before each new heating season, the chimney and flue gas connection piece should always be checked for blockages. Check the stove externally and internally for damage. Check gaskets in particular. Only original spare parts may be used.

Cleaning of ceramic logs.

Remove the ceramic logs as described in points 1 - 4 under **Service**.

Clean the ceramic parts carefully with a soft brush and a vacuum cleaner.

Only replace damaged parts with original Rais specified parts.

Pack scrap ceramics in plastic bags and deliver to the correct waste locations.

It is recommended using a vacuum cleaner with a HEPA filter system.

Replace embers and close the door. Ensure the stove works correctly and is safe to use.

Servicing of the Burners.

(See section Conversion to bottled gas if necessary)

Remove the ceramic logs as described in points 1 - 4 under **Service**.

The pilot plate guard is removed by loosening the two M5 screws with a 4 mm hex key. By removing the two screws on the pilot unit with a 7 mm open-ended spanner, the pilot unit can be raised a little. Fittings on the underside of the pilot unit can be loosened by means of a 10 mm open-ended spanner. The thermosensor and pilot burner can be replaced.

To gain access to the nozzles on the main burner, the main burner unit must be removed from the stove. This is done by removing the 4 bolts holding the burner in place. Now the burner can be lifted out of the combustion chamber. Now there is free access to the nozzles.

When parts are replaced, only replace these with original Rais specified parts.

Accessories

2796521 - 6KG heat accumulation stone for Viva 120 L, 4 in a set.

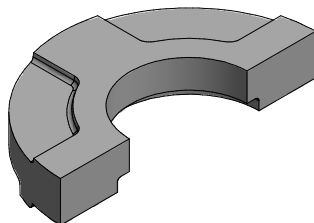

2710611SV - Stainless Classic Top plate for Rear outlet

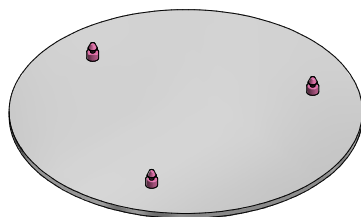

2710612SV - Stainless Classic Top plate for Top outlet

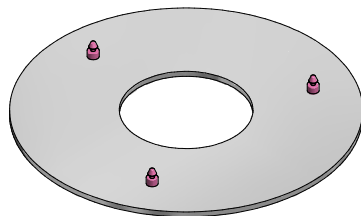

3713506 - Mains Adapter
(Connecting the stove to a network)



3713507 - MyFire Wi-Fi Box incl. cable
(App-based control of the stove)



3713595 - Propane Gas LP Conversion kit

Installation of MyFire Wi-Fi Box

Viva L Gas can be controlled remotely via an APP for your smart phone or tablet.

The MyFire Wi-Fi Box is connected to the Receiver, which is placed under the combustion chamber by opening the stove door and inserting the narrow plug on the Wi-Fi lead into the opening marked "SI".

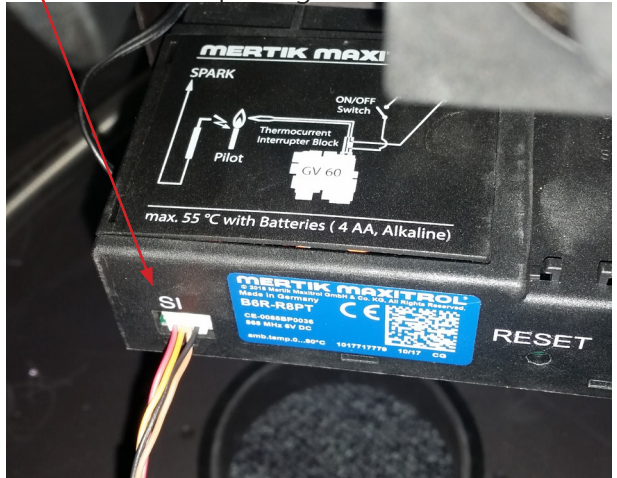

The wide plug on the Wi-Fi lead is inserted into the Wi-Fi box.

When connecting the Wi-Fi box, use the mains adapter (connection to electricity mains) which is connected to the receiver.

The mains adapter is connected to the receiver on the stove. (batteries should be removed from the receiver to avoid leakage of batteries over time)

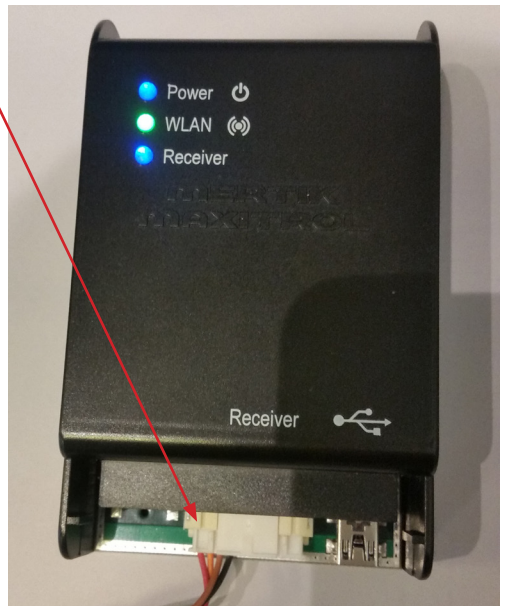

CONFIGURATION OF THE MYFIRE APP

NB!

When configuring the MyFire app you will need the SSID key and access code for the wireless network (Wi-Fi).

There are more detailed configuration and guidance instructions at www.myfireapp.com

START-UP CONFIGURATION

1. Download the MyFire app from the Apple App Store or Google Play Store.
2. Touch the screen to start configuration of the app.
3. Choose language, temperature (C° or F°) and time format (12 or 24 hours).

REGISTRATION

NOTE: You must register the appliance before you can log in. Registration is a one-off procedure.

1. Complete data and accept our Privacy Policy.
2. Touch "OK" in the pop-up message.
3. Press on the link to confirm verification of the e-mail address.
4. Now you will be shown a message that the MyFire app is registered.
5. Go back to the app.

LOGIN

1. Complete the access code for registration.
2. Accept "Terms and Conditions".
3. Press the "Login" button

CONNECT THE SMART UNIT TO THE NEW MYFIRE WI-FI BOX

1. Touch the icon ⊕
2. A message tells you that you need to enter the Wi-Fi settings for the SMART unit.
3. Touch `myfire_Wifi-Box_<number>`.
4. Enter the access code "MYFIREPLACE"

CONNECT THE MYFIRE WI-FI BOX TO THE WI-FI ROUTER

NOTE: The connection process can take between 1-10 minutes. Once the connection has been made, a pop-up message will tell you to enter the Wi-Fi settings for the SMART unit.

1. Select a name for your stove.
2. Write the name (SSID) on your Wi-Fi router.
3. Write the access code for your Wi-Fi router.
4. Press the "Connect" button.

NB!

In order to connect the MyFire Wi-Fi box to the Wi-Fi router (home network) you need to ensure:

- That a home network is available.
- That the name and access code of the home network are correct.
- That the Wi-Fi router's SSID key is not hidden.
- That the home network's signal is within range.
- That the Wi-Fi router supports the UDP protocol (User Datagram Protocol).

CONNECT SMART UNIT TO MYFIRE WI-FI BOX

NOTE: Once the connection has been made a pop-up message will tell you to enter the Wi-Fi settings for the SMART unit.

1. Touch the "OK" button if this is correct.

CONFIRM THE SETTINGS FOR THE FIREPLACE

1. After confirming the settings for fireplace, touch the "Finish" button.

A LIST OF CONNECTED MYFIRE WI-FI BOXES IS DISPLAYED

1. Touch the "Start App" button to finish the installation and configuration process.

The start screen is displayed and the MyFire app is ready to use.

NB!

Once the MyFire Wi-Fi box and MyFire app have been configured, the time should be configured in the settings in the MyFire app.

NB!

The active unit (Symax handset or SMART unit) is the last one used. The exception is however if the non-active unit is used to change the light, ventilator or AUX. The non-active unit makes the changes but the active unit remains unchanged if it is in Thermostatic, Program or Eco Mode. If a Profile contains a Thermostatic program or Eco setting, this will also contribute to the active unit remaining active.

NB!

If Thermostatic, Program or Eco mode are activated using the app, the corresponding icon and "APP" are displayed on the handset (see figure 25)



Figure 25: The app is connected (in Thermostatic mode)

NB!

When the motor is running, no information is exchanged between sender and receiver. Synchronisation takes place once the motor has stopped.

NB!

Room temperature data is transferred by the handset during synchronisation.

Mounting of 6KG heat accumulation stones

Remove the top plate. Place the two steel brackets, in the slits in the top of the burning chamber, as shown.

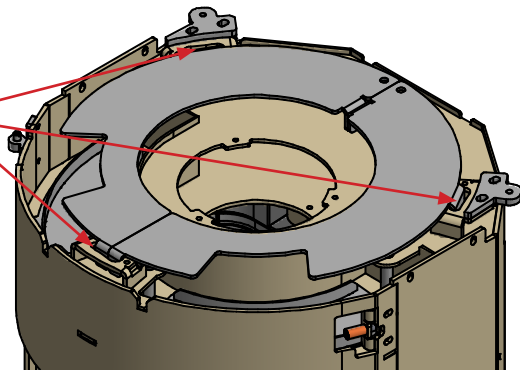

Place the first layer of stones perpendicular to the division of the steel plates.

Place the second layer of stones perpendicular to the division of the first layer.

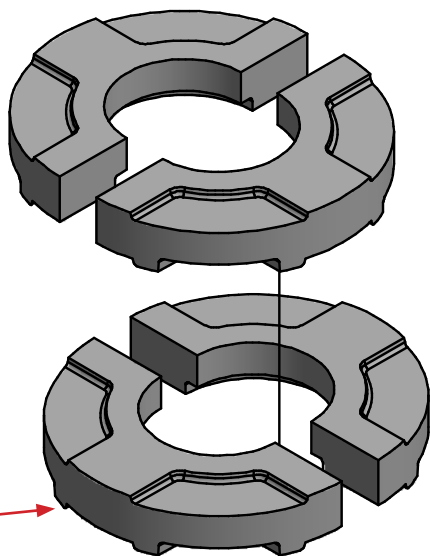

99-MODULWS

1712402

1712401

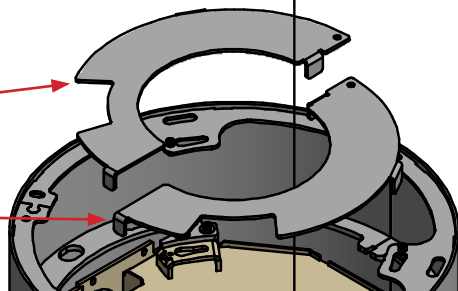

Spare parts list:

Viva 100 L gas - VIVA 120 L gas - VIVA 160 L gas

If spare parts other than those recommended by RAIS are used, the guarantee will be invalidated.

All replaceable parts can be purchased as spare parts from your RAIS dealer.

See spare part drawings (back of the manual).

xx: optional colour code

Pos.	Number	Article no.	Description
1	1	37120xx	Glass door
2	1	37121xx	Classic Glass door
3	1	2710601xx	Top plate for rear outlet
4	1	2710602xx	Top plate for top outlet
5	1	2720601xx	Top plate for rear outlet - Embossed
6	1	2720602xx	Top plate for top outlet - Embossed
7	1	1715500	Gasket set for Glass door
8	1	1715500-2	Gasket set for Glass door - Classic

Spare parts list:

VIVA 100 L G Gas - 120 L G Gas - 160 L G Gas

If spare parts other than those recommended by RAIS are used, the guarantee will be invalidated.

All replaceable parts can be purchased as spare parts from your RAIS dealer.

See following spare part drawings (back of the manual).

xx: optional colour code

Pos.	Number	Article no.	Description
1	1	37120xx	Glass door
2	1	37121xx	Classic Glass door
3	1	2710601xx	Top plate for rear outlet
4	1	2710602xx	Top plate for top outlet
5	1	2720601xx	Top plate for rear outlet - Embossed
6	1	2720602xx	Top plate for top outlet - Embossed
7	1	1715500	Gasket set for Glass door
8	1	1715500-2	Gasket set for Glass door - Classic
9	1	1715500-4	Gasket set for side glass - Glass
10	1	1715500-5	Gasket set for side glass - Classic
11	2	3715002	Internal glass t/side
12	1	1715003	Left side glass
13	1	1715004	Right side glass
14	1	1712701xx	Steel side - left
15	1	1712702xx	Steel side - right

Spare parts list:

VIVA L Gas - Gas unit

If spare parts other than those recommended by RAIS are used, the guarantee will be invalidated.

All replaceable parts can be purchased as spare parts from your RAIS dealer.

Pos.	Number	Article no.	Description
1		3713504	Ceramic Log + Ember set
2		G30-ZP2-312	Pilot Assembly Natural
3		G30-ZP2-271	Pilot Assembly LPG
4		G30-SPK1	Electrode
5		G60-ZKIS1/1500	Electrode Lead
6		CG30182	Thermocouple
7		YG46177	Injector Natural Front
8		NG05077	Injector Natural Left & Right
9		RG10077	Injector LPGFront
10		WG04077	Injector LPG Left & Right
11		RA10092	Burner Top Assembly Front
12		RA10L76	Burner Raised Assembly Left
13		RA10R76	Burner Raised Assembly Right
14		RK10P07	Complete Burner Assembly Natural RK10N07 Complete Burner Assembly LPG
15		RK10-SEAL-05	Burner Seal Set
16		3711213	Grate Assembly
17		RK10_N1_GV60	Gas Valve Assembly Natural
18		RK10_P1_GV60	Gas Valve Assembly LPG
19		GV-S60C/12	Latching Solenoid
20		G6R-R4AS	Receiver unit
21		G6R-H4D	Handset

Technical Information

Country	Natural	LPG
AT -Austria	I2H, G20 at 20 mbar	I3P(50),G31 at 50 mbar; I3B/P(50),G30/G31 at 50 mbar
BE -Belgium	I2E+, G20/G25 at 20/25 mbar	I3+,G31/G31 at 28/37 mbar; I3P-(37),G31 at 37 mbar; I3B/P(30),G30/G31 at 30 mbar
BG -Bulgaria	I2H, G20 at 20 mbar	I3B/P(30),G30/G31 at 30 mbar
CH - Switzerland	I2H, G20 at 20 mbar	I3P(50),G31 at 50 mbar; I3+,G31/G31 at 28/37 mbar; I3P(37),G31 at 37 mbar; I3B/P(50),G30/G31 at 50
CY -Cyprus	I2H, G20 at 20 mbar	I3+,G31/G31 at 28/37 mbar; I3B/P(30),G30/G31 at 30 mbar
CZ -Czech Republic	I2H, G20 at 20 mbar	I3P(50),G31 at 50 mbar; I3+,G31/G31 at 28/37 mbar; I3P(37),G31 at 37 mbar; I3B/P(50),G30/G31 at 50
DE -Germany	I2ELL, G25 at 20 mbar ¹ ; I2E, G20 at 20 mbar ¹	3P(50),G31 at 50 mbar; I3B/P(50),G30/G31 at 50
DK -Denmark	I2H, G20 at 20 mbar	I3B/P(30),G30/G31 at 30 mbar
EE -Estonia	I2H, G20 at 20 mbar	I3B/P(30),G30/G31 at 30 mbar
ES -Spain	I2H, G20 at 20 mbar	I3+,G31/G31 at 28/37 mbar; I3P-(37),G31 at 37 mbar
FI -Finland	I2H, G20 at 20 mbar	I3P(30),G31 at 30 mbar; I3B/P(30),G30/G31 at 30 mbar
FR -France	I2E+, G20/G25 at 20/25 mbar	I3+,G31/G31 at 28/37 mbar; I3P-(37),G31 at 37 mbar; I3B/P(30),G30/G31 at 30 mbar; I3B/50),G30/G31 at 50
GB -United Kingdom	I2H, G20 at 20 mbar	I3+,G31/G31 at 28/37 mbar; I3P(37),G31 at 37 mbar; I3B/P(30),G30/G31 at 30 mbar
GR -Greece	I2H, G20 at 20 mbar	I3+,G31/G31 at 28/37 mbar; I3P(37),G31 at 37 mbar; I3B/P(30),G30/G31 at 30 mbar

Country	Natural	LPG
GR -Greece	I2H, G20 at 20 mbar	I3+,G31/G31 at 28/37 mbar; I3P(37),G31 at 37 mbar; I3B/P(30),G30/G31 at 30 mbar
HU-Hungary		I3B/P(30),G30/G31 at 30 mbar
HR -Croatia	I2H, G20 at 20 mbar	I3P(37),G31 at 37 mbar; I3B/P(30),G30/G31 at 30 mbar
IE -Ireland	I2H, G20 at 20 mbar	I3+,G31/G31 at 28/37 mbar; I3P(37),G31 at 37 mbar
IS -Iceland		
IT -Italy	I2H, G20 at 20 mbar	I3+,G31/G31 at 28/37 mbar; I3P(37),G31 at 37 mbar; I3B/P(30),G30/G31 at 30 mbar
LT -Lithuania	I2H, G20 at 20 mbar	I3+,G31/G31 at 28/37 mbar; I3P(37),G31 at 37 mbar; I3B/P(30),G30/G31 at 30 mbar
LU -Luxembourg	I2E, G20 at 20 mbar	
LV -Latvia	I2H, G20 at 20 mbar	
MT -Malta		I3B/P(30),G30/G31 at 30 mbar
NL -The Netherlands	I2L, G25 at 25 mbar I2EK, G25.3 at 25 mbar	I3P(50),G31 at 50 mbar; I3P(30),G31 at 30 mbar; I3P(37),G31 at 37 mbar; I3B/P(30),G30/G31 at 30 mbar
NO-Norway	I2H, G20 at 20 mbar	I3B/P(30),G30/G31 at 30 mbar
PL -Poland	I2E, G20 at 20 mbar	I3P(37),G31 at 37 mbar
PT -Portugal	I2H, G20 at 20 mbar	I3+,G31/G31 at 28/37 mbar; I3P(37),G31 at 37 mbar
RO -Romania	I2E, G20 at 20 mbar	I3P(30),G31 at 30 mbar; I3B/P(30),G30/G31 at 30 mbar
SE - Sweden	I2H, G20 at 20 mbar	I3B/P(30),G30/G31 at 30 mbar
SL -Slovenia	2H, G20 at 20 mbar	I3+,G31/G31 at 28/37 mbar; I3P(37),G31 at 37 mbar; I3B/P(30),G30/G31 at 30 mbar
SK -Slovakia	I2H, G20 at 20 mbar	I3P(50),G31 at 50 mbar; I3+,G31/G31 at 28/37 mbar; I3P(37),G31 at 37 mbar; I3B/P(30),G30/G31 at 30 mbar; I3B/P(50),G30/G31 at 50
TR -Turkey	I2H, G20 at 20 mbar	I3+,G31/G31 at 28/37 mbar; I3P(37),G31 at 37 mbar; I3B/P(30),G30/G31 at 30 mbar

Technical Data

Product Identification Number: 0359CS1717

Viva L Gas

Gas type (Natural Gas - LNG)		G20 I2H,I2E	G20/G25 I2E+	G25/G25.3 I2L/ I2EK	G20/G25 I2ELL
Supply Pressure	mbar	20	20/25	25	20
Nominal Heat Input Gross (Hs)	kW	9.1	9.1 / 8.4	8.5	7.5
Nominal Heat Input Nett (Hi)	kW	8.2	8.2 / 7.6	7.7	6.8
Consumption	m ³ /hr	0.84	0.840 / 0.905	0.89	0.8
Burner Pressure (hot)	mbar	13.2	13.2 / 16.4	16.6	13.4
Injector Marking		120 Centre, 260 Left, 260 Right			
Pilot		G30 ZP2 312 (31.2 inj)			
Efficiency Class		2			
Nox Class		5			
Type		C11 / C31			

Gas type (City gas)		G150.1
Supply Pressure	mbar	8
Nominal Heat Input Gross (Hs)	kW	9.4
Nominal Heat Input Nett (Hi)	kW	8.4
Consumption	m ³ /hr	1.5
Burner Pressure (hot)	mbar	3.5
Injector Marking		320 Centre, 700 Left, 700 Right
Pilot		G150.1 CG (inj. 27.1 - 90)
Efficiency Class		1
Nox Class		5
Type		C11 / C31

Gas type (liquid petroleum gas - LPG)		G30/G31 I3B/P(30)	G30/G31 I3+	G31 I3P(50)	G31 I3P(37)	G31 I3P(30)
Supply Pressure	mbar	30	30 / 37	50	37	30
Nominal Heat Input Gross (Hs)	kW	8	8	8	8	7
Nominal Heat Input Nett (Hi)	kW	7.4	7.4	7.4	7.4	6.5
Consumption	m ³ /hr	0.225	0.225 / 0.29	0.29	0.29	0.253
Burner Pressure (hot)	mbar	27	27 / 36	36	36	28
Injector Marking	80 Centre, 100 Left, 100 Right					
Pilot	G30 ZP2 271 (27.1 inj)					
Efficiency Class	2					
Nox Class	5					
Type	C11 / C31					

This stove has been tested and certified for use with natural gas, City gas, LPG and Biopropane.

Biopropane can be used if the stove is adjusted for use with LPG (*liquid petroleum gas*), see rating plate under PROPANE

EXAMPLES OF CHIMNEY SOLUTIONS

Vertical Roof Terminal

Distance "V" 500mm - 12m (min. - Max)

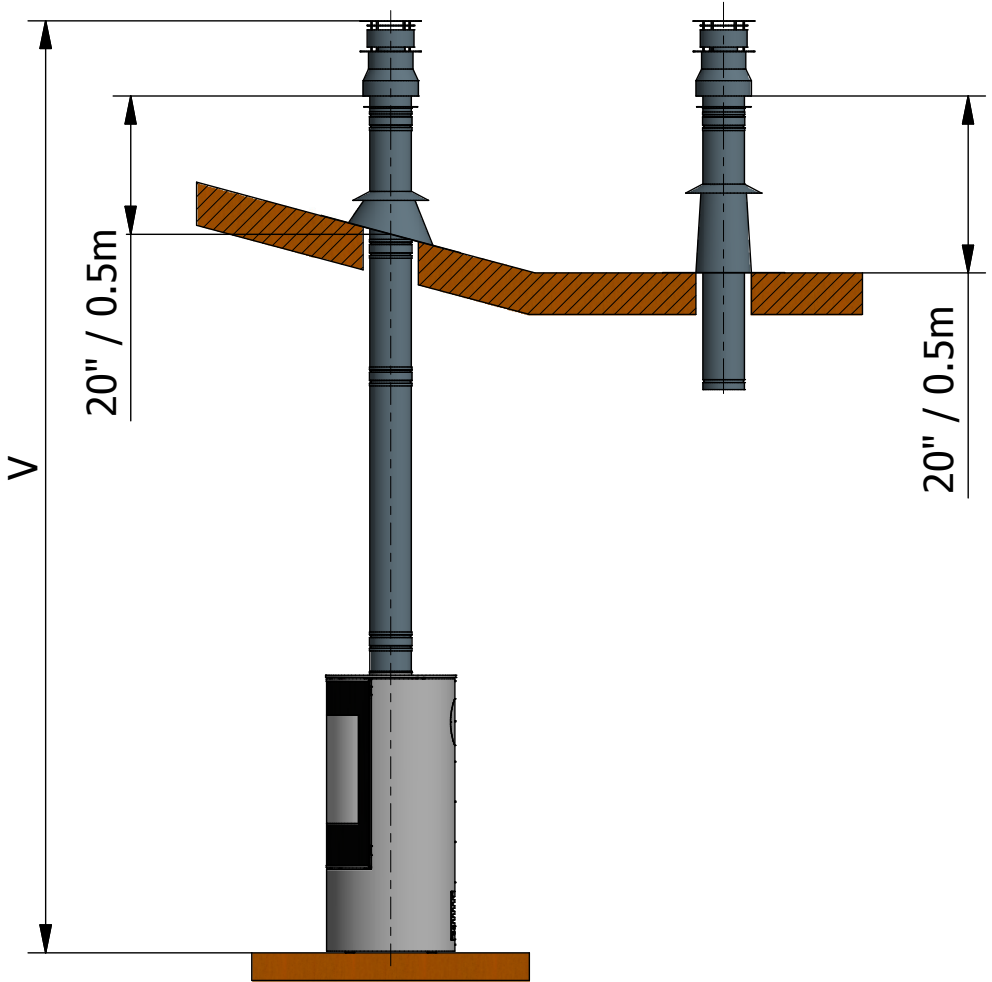

Vertical Roof Terminal (Renovation kit)

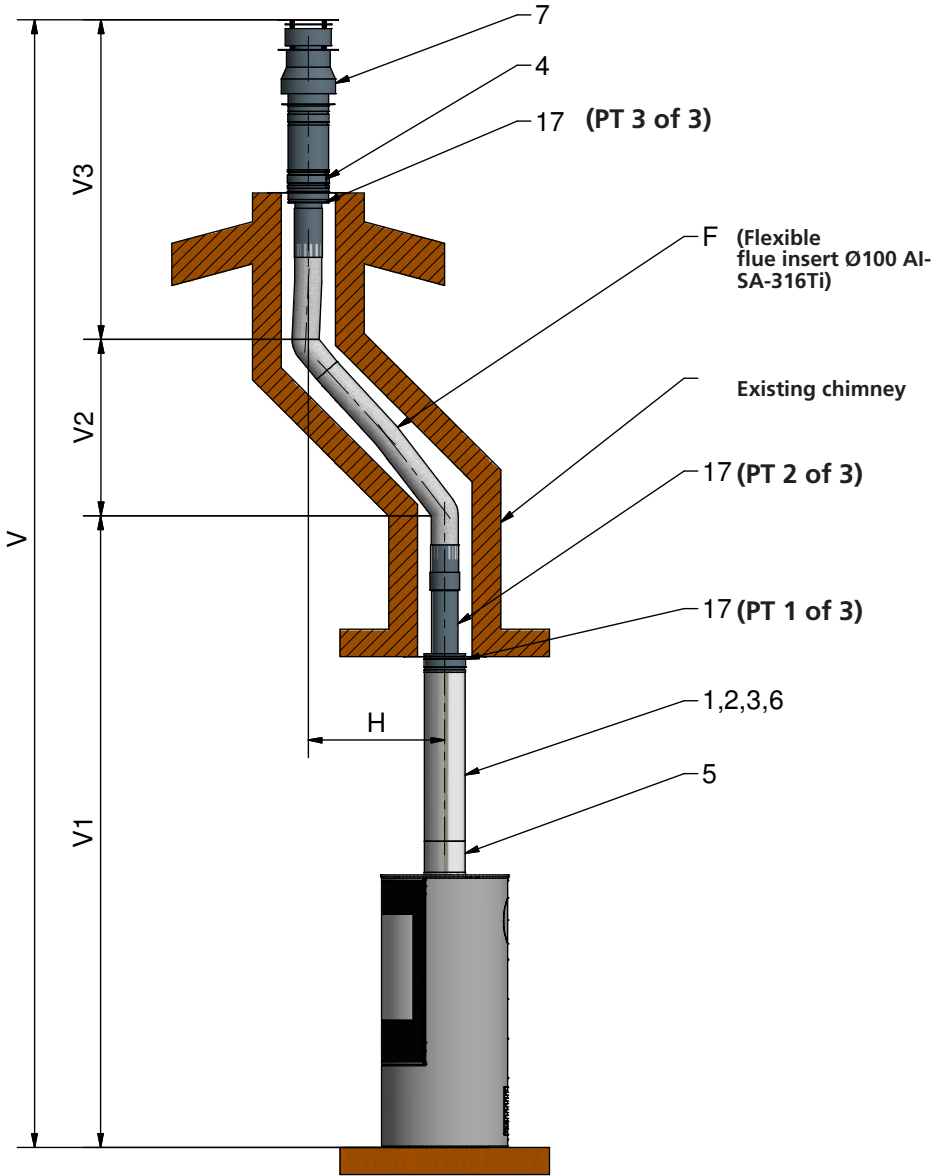

If the existing chimney is not completely sound the air inlet must also be lined (recommended)

Vertical Pitched Roof Terminal

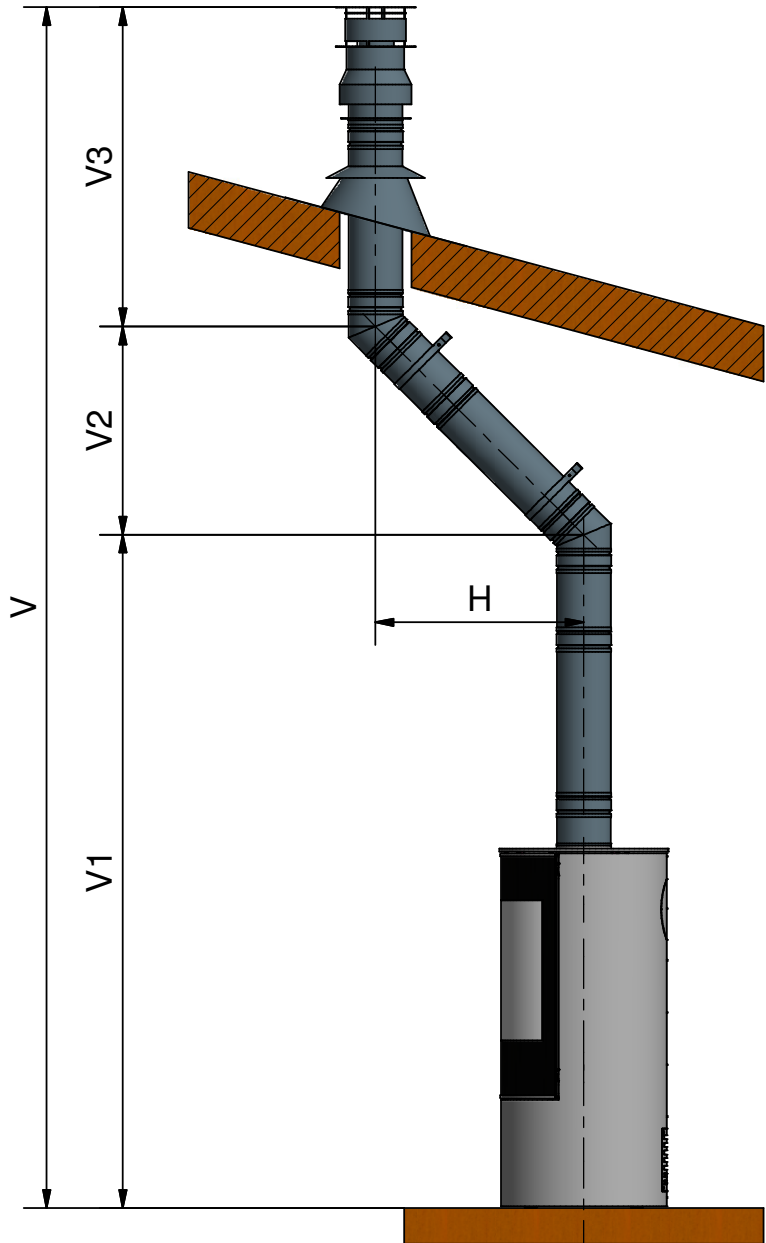

Distance "H" = 0-3m (Min - Max)
 Distance "V1" = 500mm - 10m (Min - Max)
 Distance "V2" = 200mm - 10m (Min - Max)
 Distance "V3" = 500mm - 10m (Min - Max)
 Distance "V" = (=V1+V2+V3) = 1.2m - 12m
 (Min - Max)

Distance "V" = 2 X "H" (Min)

Vertical Roof Terminal with Bend

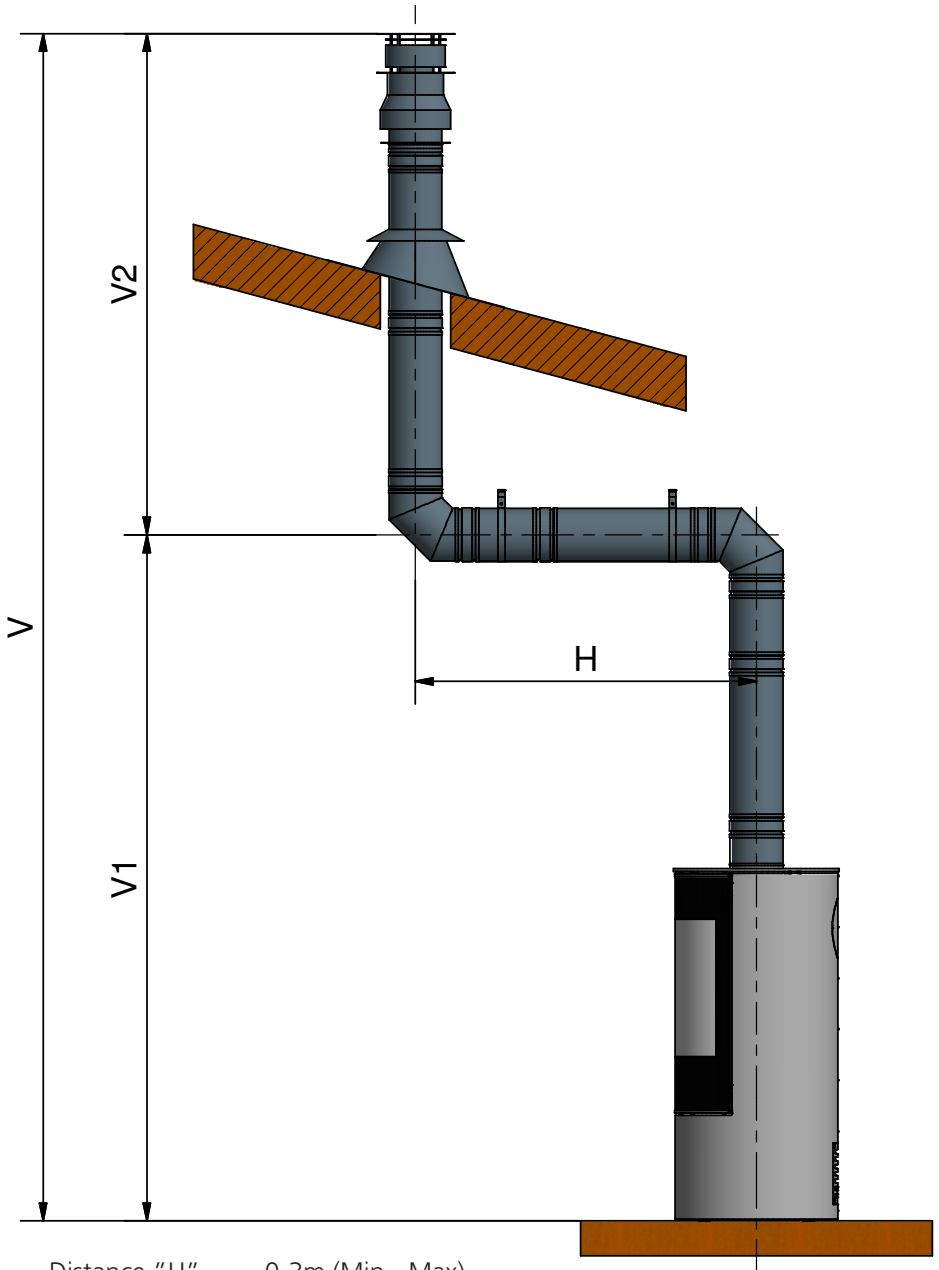

Distance "H" = 0-3m (Min - Max)
Distance "V1" = 500mm - 10m (Min - Max)
Distance "V2" = 500mm - 10m (Min - Max)
Distance "V" = (=V1+V2) = 1m - 12m (Min - Max)

67 Distance "V" = 2 X "H" (Min)

Existing chimney (Renovations kit)

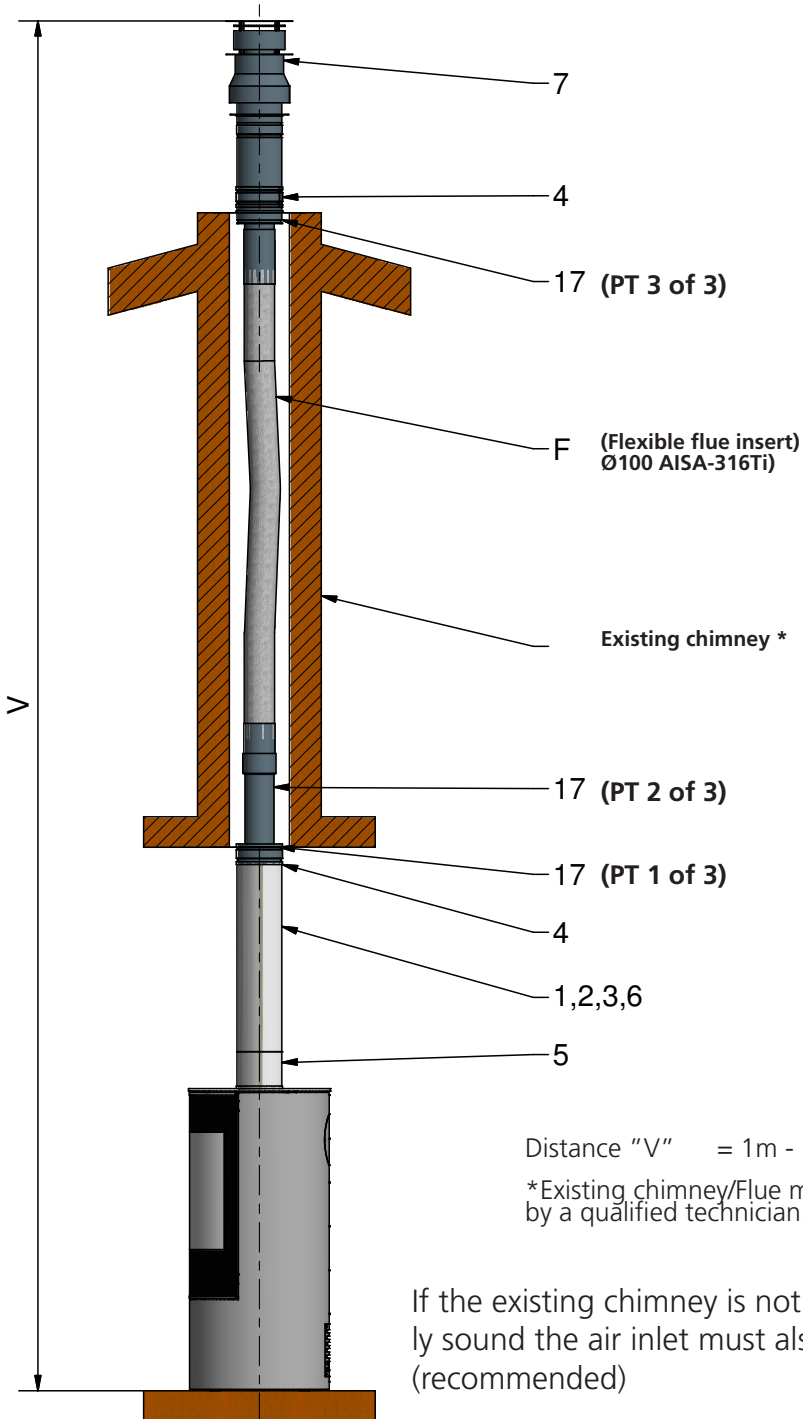

Existing chimney with Bend (Renovations kit)

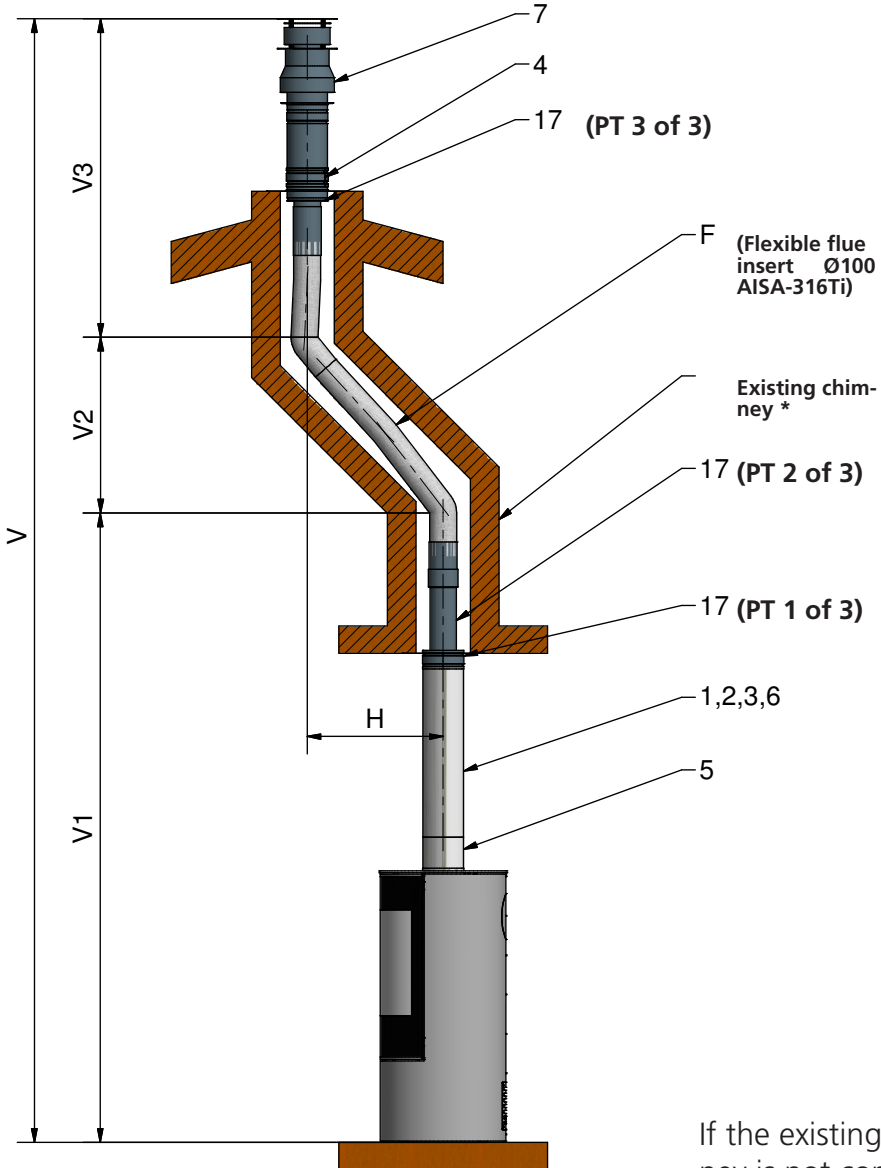

Distance "H" = 0-3m (Min - Max)
 Distance "V1" = 500mm - 10m (Min - Max)
 Distance "V2" = 200mm - 10m (Min - Max)
 Distance "V3" = 500mm - 10m (Min - Max)
 Distance "V" = (=V1+V2+V3) = 1.2m - 12m
 (Min - Max)

Distance "V" = 2 X "H" (Min)

If the existing chimney is not completely sound the air inlet must also be lined (recommended)

Vertical Roof Terminal with Back outlet

for more information see paragraph Location of chimney terminals

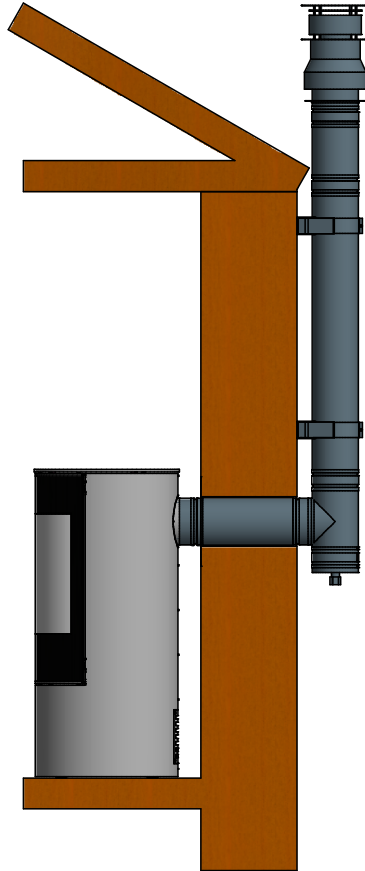

Horizontal wall Terminal

for more information see paragraph Location of chimney terminals

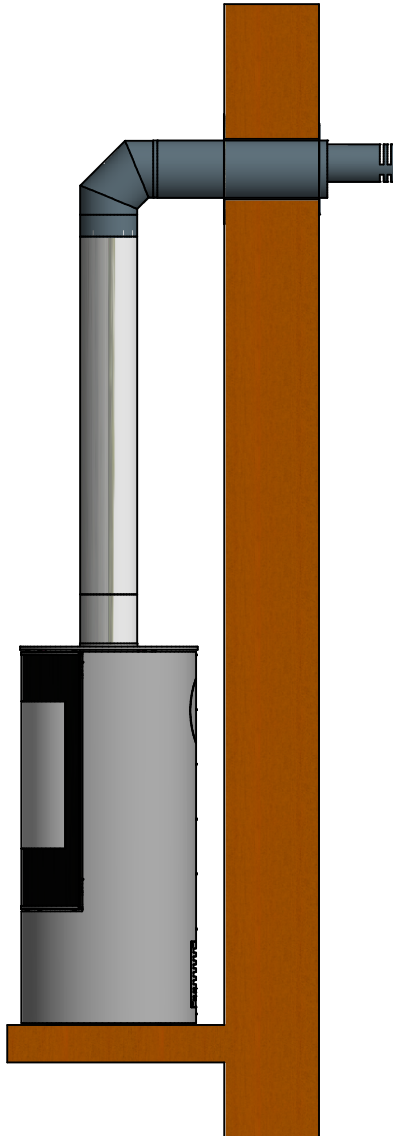

Horizontal wall Terminal

for more information see paragraph Location of chimney terminals

Top outlet

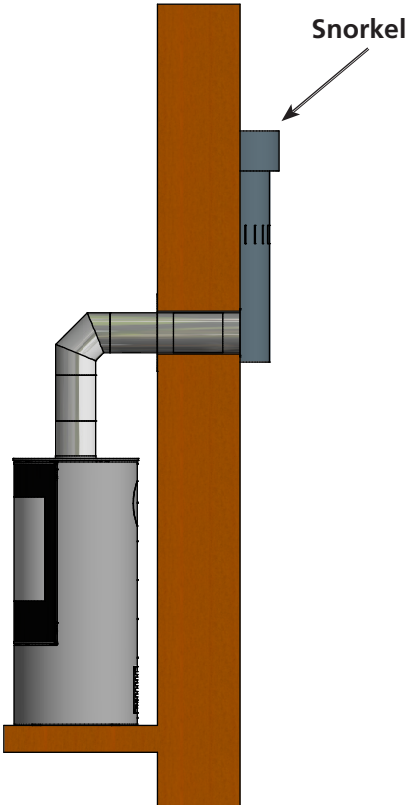

Back outlet

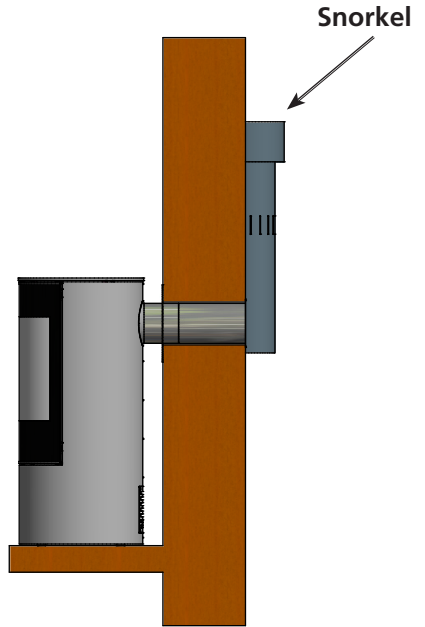

Chimney components.

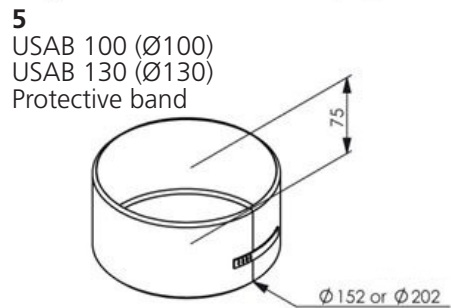
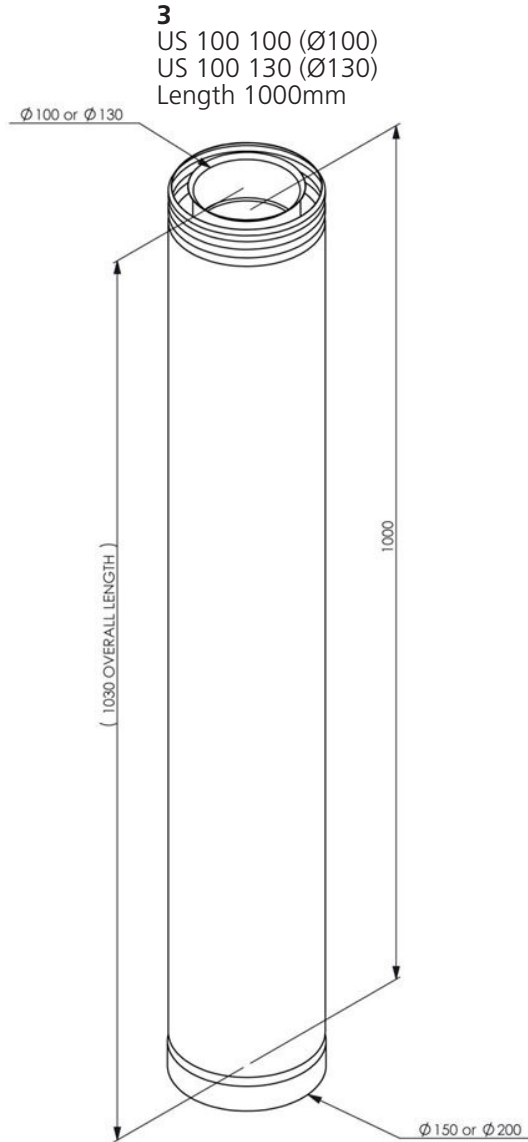
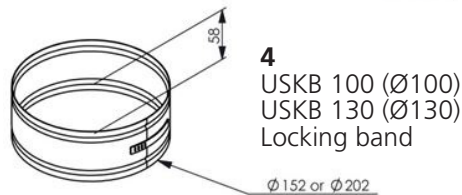
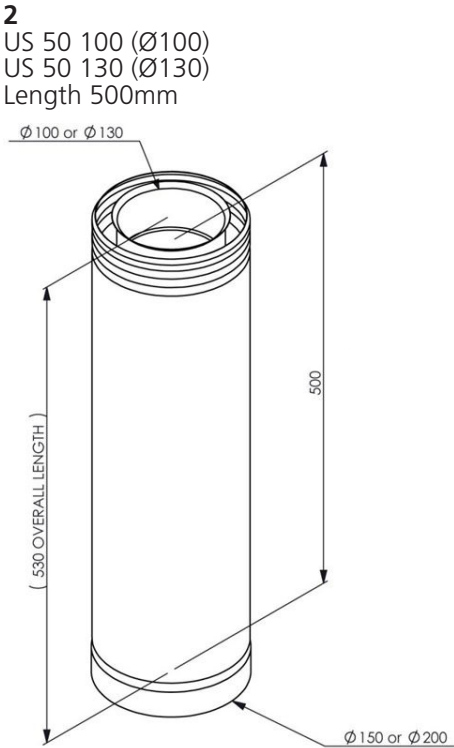
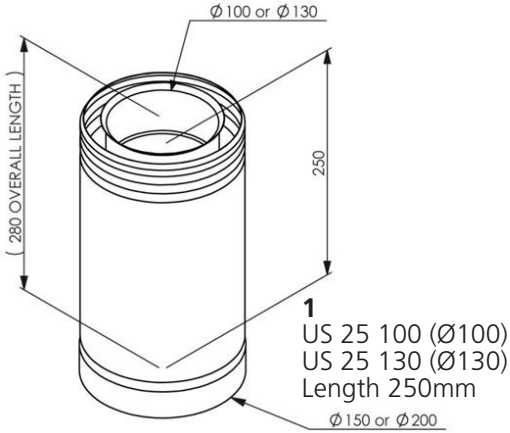

6
 USPP 100 (Ø100)
 USPP 130 (Ø130)
 Adjustable length

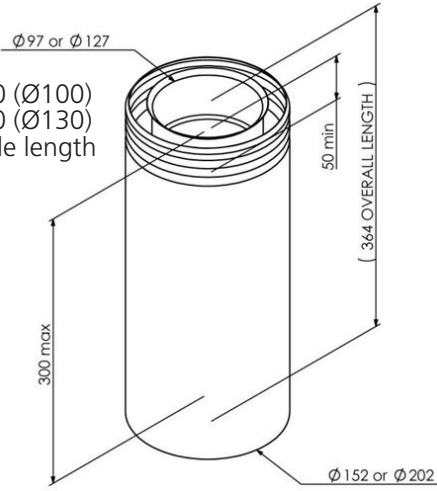

7
 USDV2 100 (Ø100)
 Vertical Terminal
 (+ USBK)

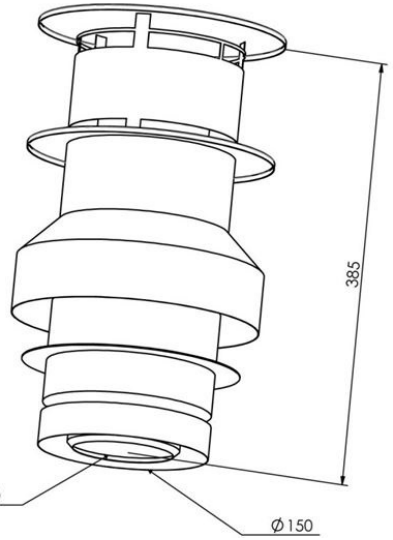

8
 USDHCE 10
 Horizontal Terminal
 (Eccentric outlet)

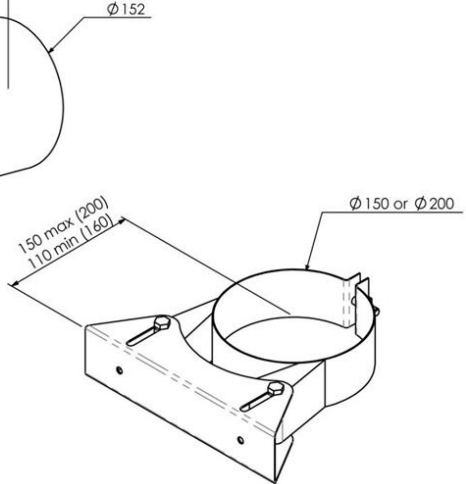
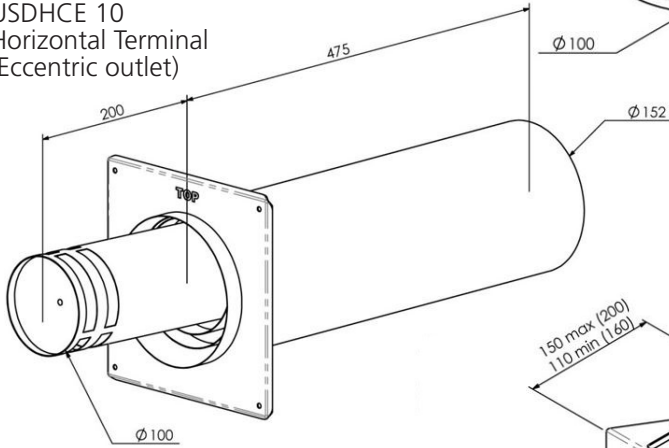

10
 USMB 100 (Ø100)
 USMB 130 (Ø130)
 Adjustable Wall Strap

9
 USEB 100 (Ø100)
 USEB 130 (Ø130)
 Fitting strap

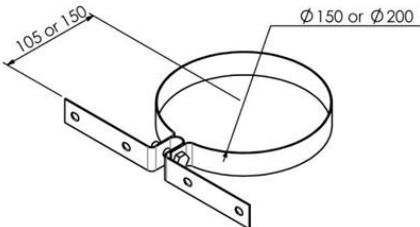

11
 USB 90 100 (Ø100)
 USB 90 130 (Ø130)
 90° elbow bend

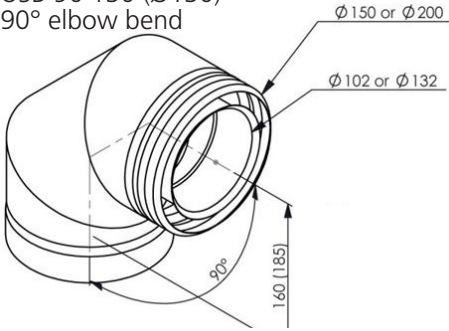

14
 USSR 100 (Ø100)
 USSR 130 (Ø130)
 Cover

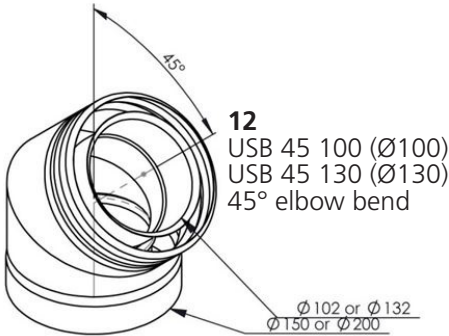
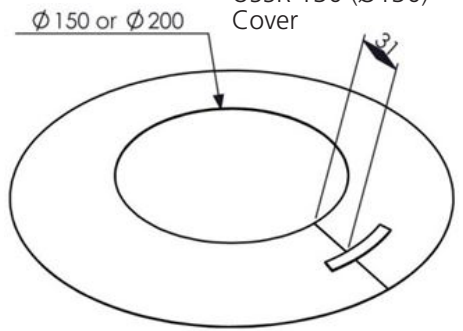

12
 USB 45 100 (Ø100)
 USB 45 130 (Ø130)
 45° elbow bend

15
 USDPAL 100 (Ø100)
 USDPAL 130 (Ø130)
 Flat roof Cover
 Aluminium

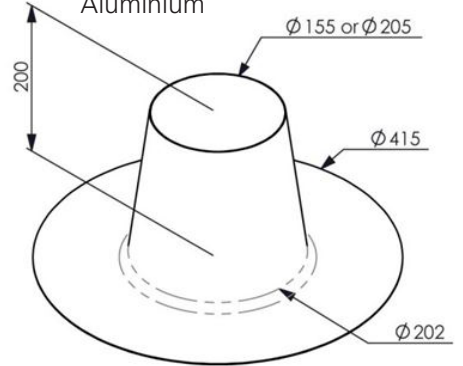

13
 USB 15 100 (Ø100)
 USB 15 130 (Ø130)
 15° elbow bend

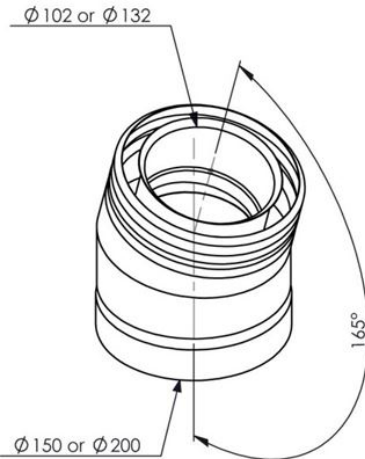

16
 USDP 100 (Ø100)
 USDP 130 (Ø130)
 Flat roof Cover

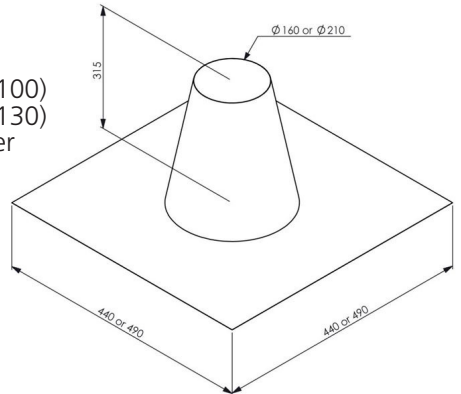

18
 USDH 100 (Ø100)
 USDH 130 (Ø130)
 Angular Cover
 5° - 30°

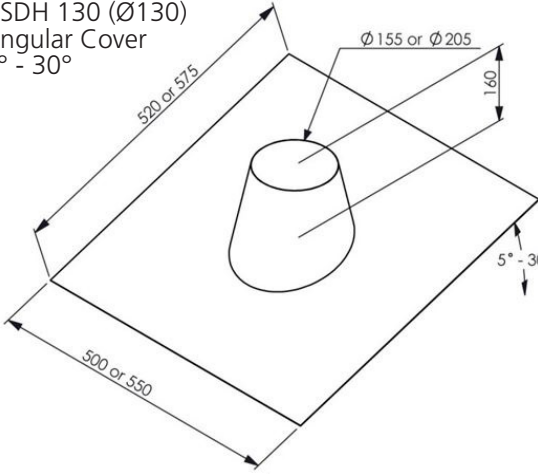

21
 USMPG 100 (Ø100)
 USMPG 130 (Ø130)
 Wall Cover

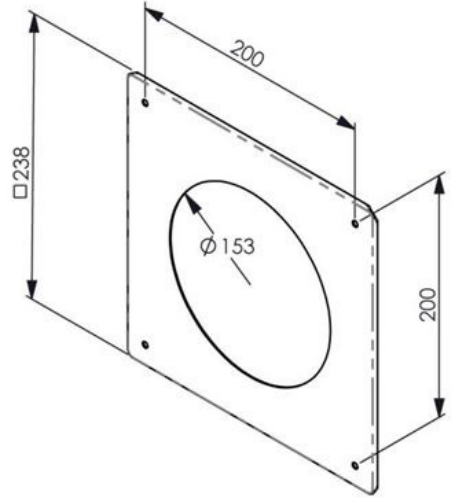

19
 USLS 100 (Ø100)
 USLS 130 (Ø130)
 Angular Cover
 20° - 45°

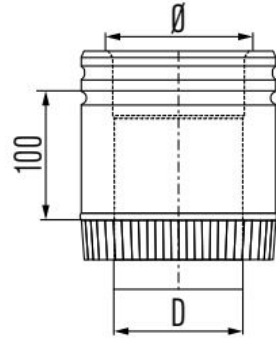
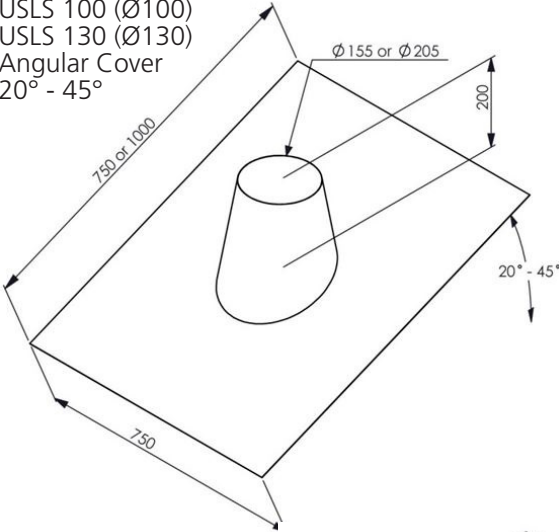

22
 ADAPTOR
 (UNIVERSAL SYSTEM ADAPTOR)
 USA Ø 100 130
 USA D 99 129

20
 USCP 100 (Ø100)
 USCP 130 (Ø130)
 Adjustable Cover
 (Supplied as a pair)

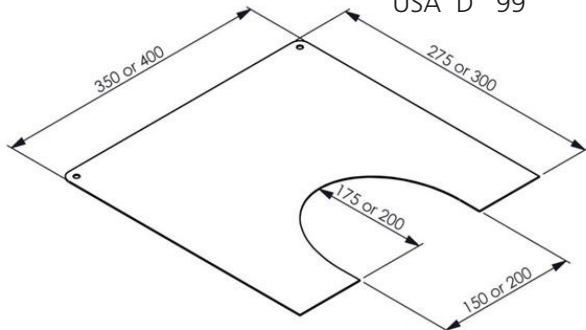

DECLARATION OF PERFORMANCE

Regulation (EU) 2009/142/EC

No.: 371

1. **Unique identification code of the product-type** VIVA 100 L Gas, Viva 100 L G Gas, Viva 100 L Classic Gas, Viva 100 L G Classic Gas, VIVA 120 L Gas, Viva 120 L G Gas, Viva 120 L Classic Gas, Viva 120 L G Classic Gas, VIVA 160 L Gas, Viva 160 L G Gas, Viva 160 L Classic Gas, Viva 160 L G Classic Gas
2. **Type** Balanced Flue Gas Stoves
3. **Intended use** Domestic room heater
4. **NPD Manufacturer** RAIS A/S Telephone +45 98 47 90 33
 Industrivej 20, Vangen Telefax +45 98 47 92 91
 DK-8900 Frederikshavn, Webmail kundeservice@rais.dk
 Denmark Homepage www.rais.com
5. **Authorised representative** n/a
6. **System of assessment AVCP** System 3
7. **Notified body** The notified laboratory *Intertek House, Cleeve Road
 Leatherhead, Surrey
 KT22 7SB, United Kingdom*
- performed the determination of the product type on the basis of type testing under system 3 and issued test report
- a. 102929617LHD-001
8. **Declared performance** Harmonized technical specification: BSEM 613: 2001+A1:2008

Essential characteristics	Performance		
Fire safety			
Reaction to fire	A1	VIVA 100 L Gas VIVA 120 L Gas VIVA 160 L Gas	VIVA 100 L G Gas VIVA 120 L G Gas VIVA 120 L G Gas
Distance to combustible materials	Rear	50	50
Minimum distances [mm] <i>For other installation settings see instruction manual</i>	Sides	250	300
	Front	700	700
Risk of burning fuel falling out	N/D		
CO-emission of combustion products	31 ppm (G20@20 full All)		
NOx emission	23 ppm (G20@20 full All)		
Surface temperature	Pass		
Electrical safety	Pass		
Cleanability	Pass		
Maximum operating pressure	- bar		
Flue gas temperature T at nominal heat output	291°C (G20@20 full All)		
Mechanical resistance (to carry a chimney/flue)	NPD		
Thermal output			
Nominal heat output	8,2 kW (G20@20 full All)		
Room heating output	8,2 kW (G20@20 full All)		
Water heating output	- kW		
Energy efficiency η	78,3 % (G20@20 full All)		

9. **The performance of the product identified in points 1 and 2 is in conformity with the declared performance in point 8. This declaration of performance is issued under the sole responsibility of the manufacturer identified in point 4.**

Signed for and on behalf of the manufacturer by:

Henrik Nergaard, Managing Director

Place FREDERIKSHAVN, DENMARK

Date 02-10-2018

Signature

Viva 100 L Gas Dimensional drawing

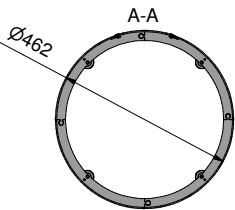
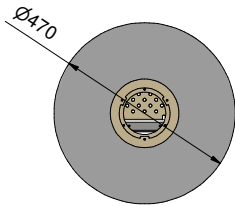
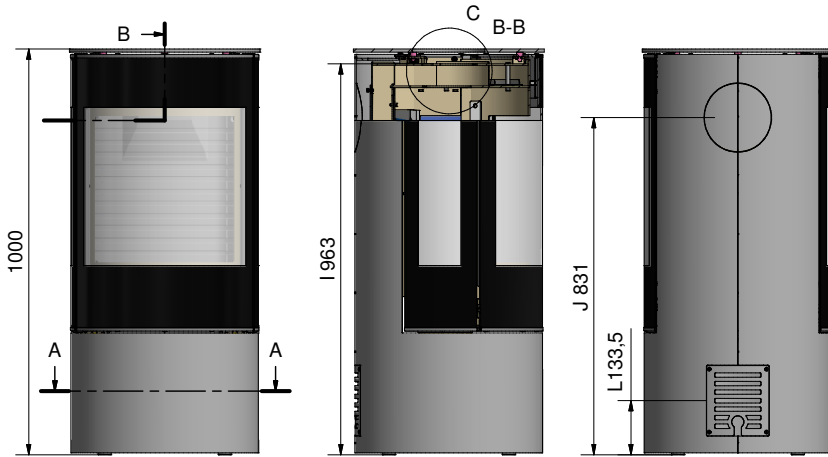

Viva 120 L Gas Dimensional drawing

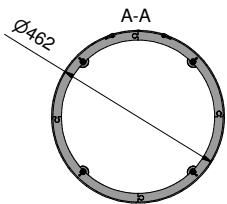
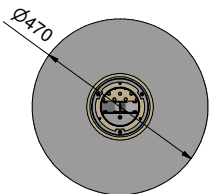
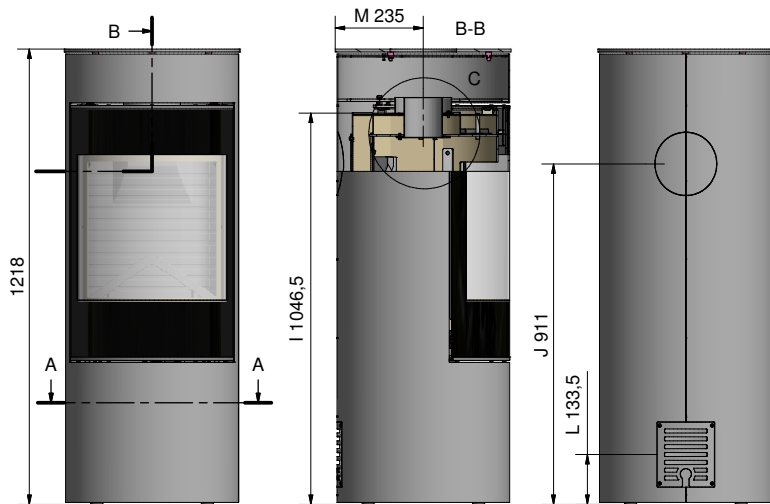

Viva 160 L Gas Dimensional drawing

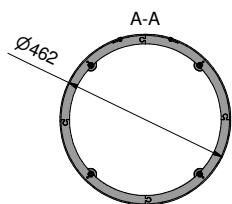
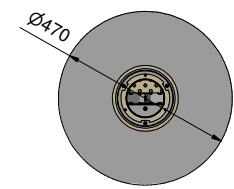
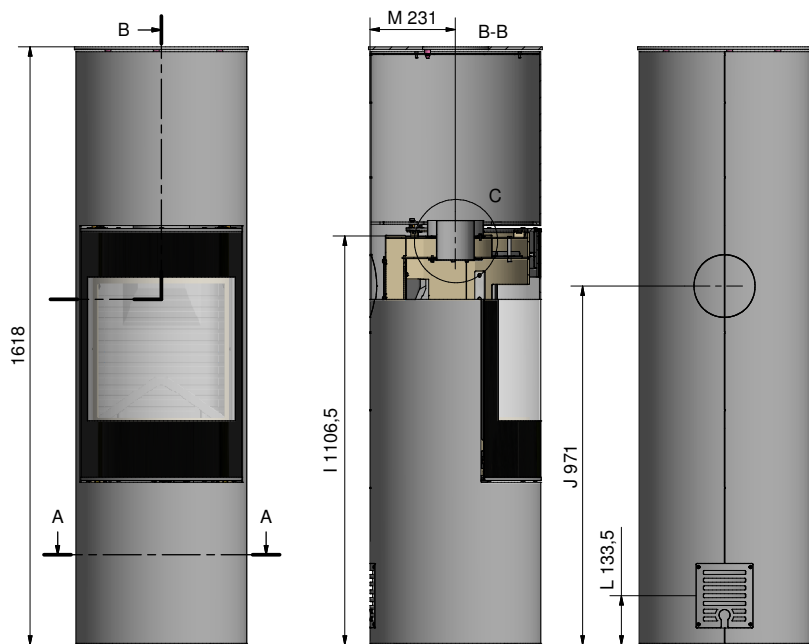

Viva 100 L Gas / Viva 120 L Gas / Viva 160 L Gas

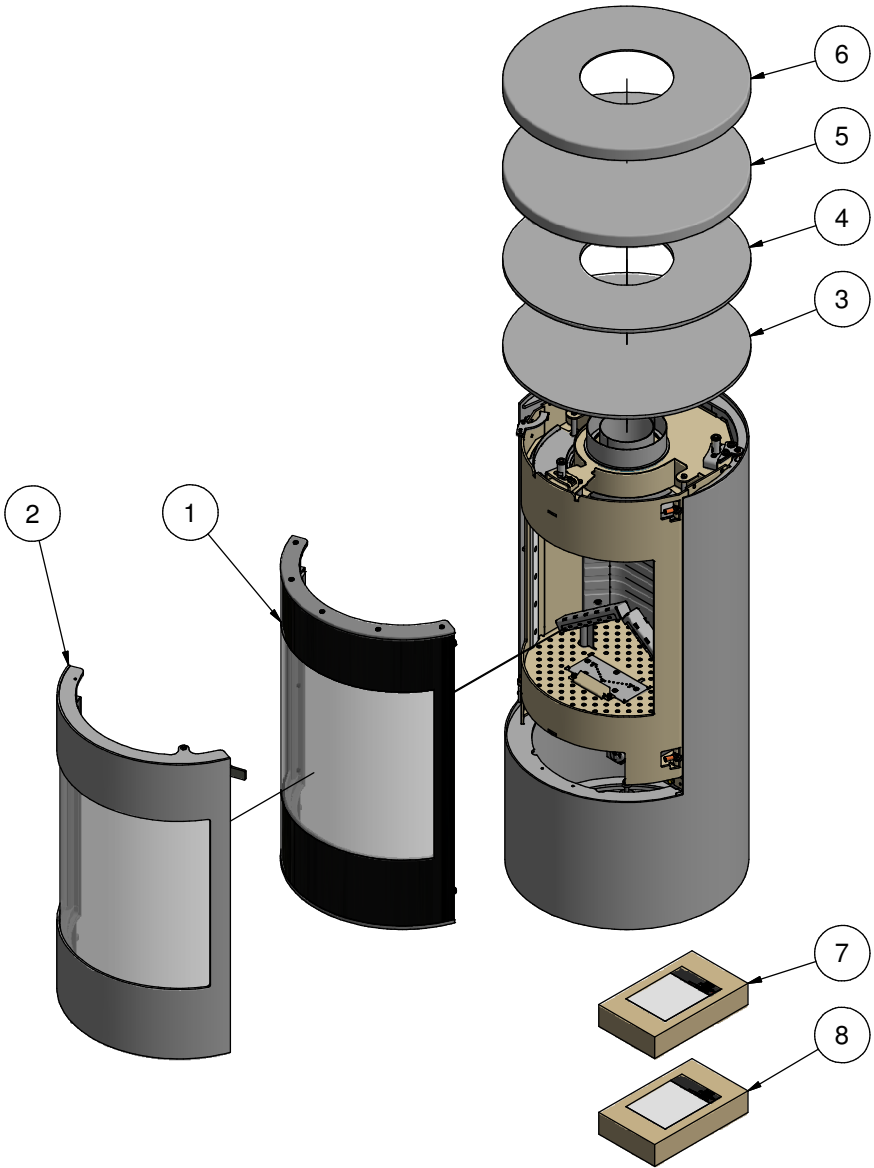

Viva 100 L G Gas / Viva 120 L G Gas / Viva 160 L G Gas

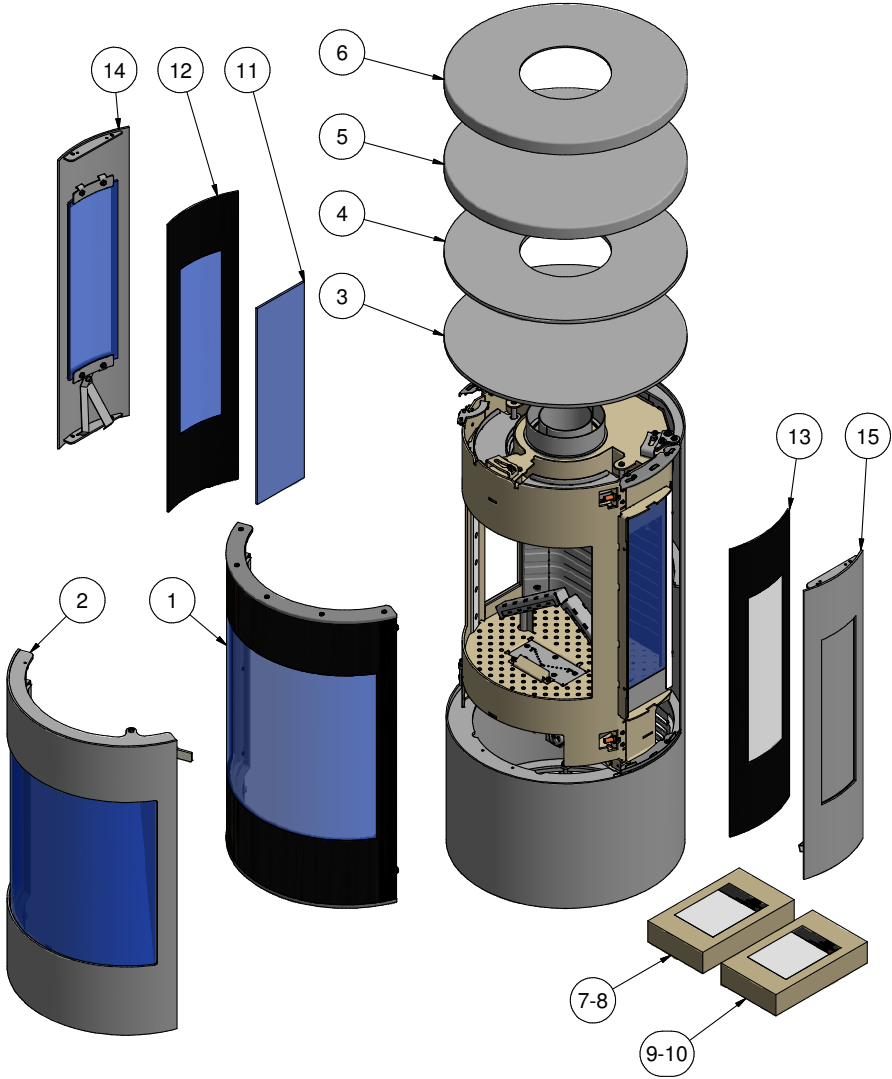



attika[®]
FEUERKULTUR

ATTIKA FEUER AG

Brunnmatt 16
CH-6330 Cham
Switzerland
www.attika.ch

RAIS[®]
ART OF  FIRE

RAIS A/S

Industrivej 20
DK-9900 Frederikshavn
Denmark
www.rais.dk